

Summary:

1.	How to connect the wires:.....	5
2.	Reference.....	6
3.	Default settings.....	7
	NMT MESSAGES.....	8
4.	Start CANopen node (keypad activation message)	8
5.	Enter pre-operational	8
6.	Reset CANopen node.....	8
7.	Stop CANopen node	9
8.	Boot-up service.....	9
9.	Heartbeat message.....	9
10.	Sync message.....	9
	PDO messages	10
11.	Keys state message.....	10
	• PKP 3500-MT.....	10
12.	Encoder 1 state message	11
13.	Encoder 2 state message	12
14.	Analog input message.....	13
15.	Set Key-LED ON message	14
	• PKP 3500-MT.....	14
16.	Set Key-LED Blink message	15
	• PKP 3500-MT.....	15
17.	Set LED encoder ON message.....	16
18.	Backlight setting	16
	SDO Messages:	17
19.	Object 2000h: Digital input module, keys states.....	17
	a) Sub 1 – Key state.....	17
	b) Sub 2 – Read encoder 1 direction counter.....	18
	c) Sub 3 – Read encoder 1 tick counter	19
	d) Sub 4 – Read encoder 2 direction counter.....	20
	e) Sub 5 – Read encoder 2 tick counter	21
	f) Sub 6 – Set/read TOP position encoder 1	21
	g) Sub 7 – Set/read TOP position encoder 2	22
20.	Object 2001h: Digital output module.....	23
	a) Set Key-LED ON.....	23
	b) Read Key-LED ON.....	23
	c) Set LED encoder ON.....	24

d) Read LED encoder ON.....	24
21. Object 2002h: Digital output module.....	25
a) Set Key-LED blink	25
b) Read Key-LED blink	25
c) Set LED encoder blink	26
d) Read LED encoder blink	26
22. Object 2003h: Brightness Level	27
a) LED indicators brightness level:	27
b) Backlight brightness level.....	27
c) Backlight color	28
d) Default backlight color	28
e) Default LED indicators brightness level	29
f) Default backlight brightness level.....	29
23. Object 2004h: Read Digital Input 8-bit.....	30
24. Object 2005h: Read Analog Input.....	31
26. Object 2006h: Set analog input message period.....	32
27. Object 2010h: Baud rate setting.....	33
28. Object 2011h: Set Boot-up service	34
29. Object 2012h: Set device active on startup.....	35
30. Object 2013h: Set CANopen node ID.....	36
31. Object 2014h: Set startup LED show	37
32. Object 2100h: Set DEMO mode.....	38
33. Object 1016h: Consumer heartbeat time.....	39
34. Object 1017h: Producer heartbeat time	40
Heartbeat message.....	40
35. Object 1000h: Device Type	41
36. Object 1001h: Error Register	41
37. Object 1008h: Manufacturer Device Name.....	41
38. Object 1009h: Manufacturer Hardware Revision.....	42
39. Object 100Ah: Manufacturer Firmware Revision	42
40. Object 100Bh: Model ID	43
41. Object 1011h: Restore default parameters.....	43
42. Object 1018h: Identity Data	44
43. Object 1400h: Receive PDO Communication Parm 0	45
44. Object 1401h: Receive PDO communication Parm 1	46
45. Object 1402h: Receive PDO communication Parm 2	47
46. Object 1403h: Receive PDO communication Parm 3	48
47. Object 1600h: Receive PDO mapping Parameter 0.....	49
48. Object 1601h: Receive PDO mapping Parameter 1	50
49. Object 1602h: Receive PDO mapping Parameter 2	51

50. Object 1603h: Receive PDO mapping Parameter 3..... 51

51. Object 1800h: 52

 a) Transmit PDO Communication Parm 0 52

 • Set periodic state transmission..... 53

52. Object 1801h: 54

 Transmit PDO Communication Parm 1..... 54

53. Object 1802h: 55

 Transmit PDO Communication Parm 2..... 55

54. Object 1803h: 56

 Transmit PDO Communication Parm 2..... 56

55. Object 1A00h Transmit PDO Mapping Parameter 0..... 57

56. Object 1A01h Transmit PDO Mapping Parameter 1..... 57

57. Object 1A02h Transmit PDO Mapping Parameter 2..... 58

58. Object 2200h: Serial number string..... 59

APPENDIX: DEMO Mode instructions..... 60

APPENDIX 2: Input application examples..... 61

59. Revision history..... 63

NOTE: this document complies with the following CAN in Automation (CiA) specifications:

- 301 (CANopen application layer and communication profile)
- 401 (Device profile for generic I/O modules)

1. How to connect the wires:



Power Supply Connector		
Connector: AMPHENOL AT04-4P or DEUTSCH DT04-4P		
PIN	COLOUR	FUNCTION
1	Blue	CAN L
2	White	CAN H
3	Black	Negative battery
4	Red	Vbatt. (12-24V)



Input Signal Connector		
Connector: MOLEX 39-013-069 (or -063)		
PIN	COLOUR	FUNCTION
1	Red	Power +5V
2	Yellow	IN0
3	Blue	IN1
4	Grey	IN2
5	Green	IN3
6	Black	GND



Warning: the input voltage range is from 0V to 5V. Do not connect input signals beyond these limits. Damage to the device may occur.

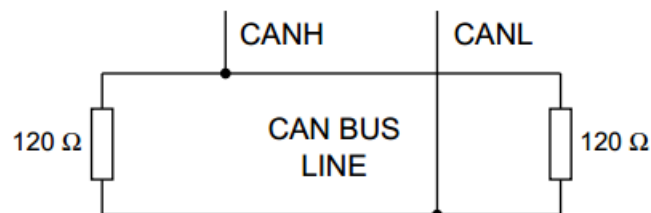

Each end of the CAN bus is terminated with 120Ω resistors in compliance with the standard to minimize signal reflections on the bus. You may need to place a 120Ω resistor between CAN-L and CAN-H.



Warning: to avoid breakage do not tighten the backshell nuts with a torque exceeding 1.8 Nm!

2. Reference

Front view.

PKP3500-MT

KEY:

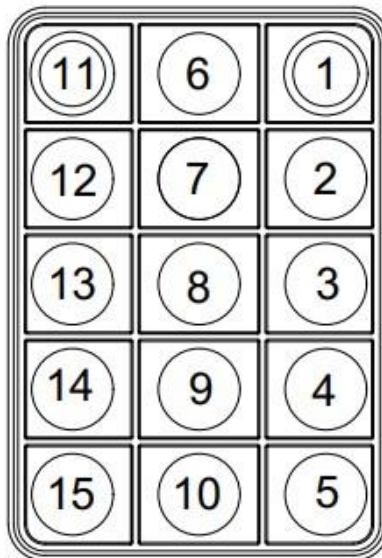

LED:

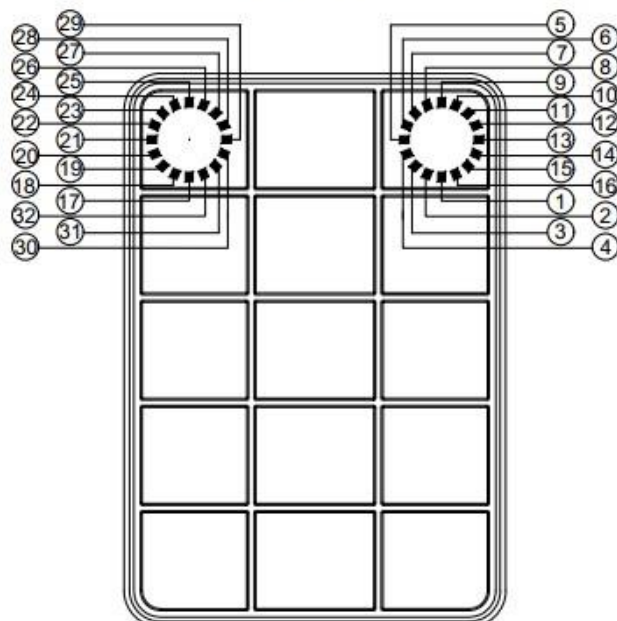

3. Default settings

Setting	Default state or level	How to change
Baud Rate	125 kbit/s	Object 2010h
CANopen Node ID	15h	Object 2013h
Device active on startup	Not active	Object 2012h
Default LED indicators brightness	3Fh (Maximum Brightness)	Object 2003h
Default backlight brightness	00h (OFF)	Object 2003h
Default backlight color	Amber	Object 2003h
Startup LED Light Show	Complete LED Sequence	Object 2014h
Periodic key-state transmission	Disabled	Object 1800h
DEMO mode	Disabled	Object 2100h
Heartbeat producer	Disabled	Object 1017h
Heartbeat consumer	Disabled	Object 1016h
Boot-up service	Active	Object 2011h
RPDO 200h transmission type	Event-driven	Object 1400h
RPDO 300h transmission type	Event-driven	Object 1401h
TPDO 180h transmission type	Event-driven	Object 1800h
TPDO 480h transmission type	Periodic (80ms)	Object 2006h
TOP position encoder 1	08h	Object 2000h
TOP position encoder 2	08h	Object 2000h

NMT MESSAGES

The Network Management messages follow a master-slave structure. Through NMT services, CANopen devices are initialized, started, reset or stopped. NMT messages have CAN-ID always equal to 00h.

4. Start CANopen node (keypad activation message)

Identifier	00h	
Byte 0	01h	Start CANopen node
Byte 1	XXh	Keypad CAN ID 00h: start all the keypads 15h: start the keypad with CAN ID = 15h.
Byte 2, 7	00h	Not used

Example:

Direction	Identifier	Format	Message
To Keypad	0	Std	01 15

5. Enter pre-operational

Identifier	00h	
Byte 0	80h	Enter pre-operational
Byte 1	XXh	Keypad CAN ID 00h: enter all the keypads 15h: enter the keypad with CAN ID = 15h.
Byte 2, 7	00h	Not used

Example:

Direction	Identifier	Format	Message
To Keypad	0	Std	80 15

6. Reset CANopen node

Identifier	00h	
Byte 0	81h	Reset CANopen node
Byte 1	XXh	Keypad CAN ID 00h: reset all the keypads 15h: reset the keypad with CAN ID = 15h.
Byte 2, 7	00h	Not used

Example:

Direction	Identifier	Format	Message
To Keypad	0	Std	81 15

7. Stop CANopen node

Identifier	00h	
Byte 0	XXh	02h: Stop CANopen node
		00h: Stop CANopen node (old PKP sw compatibility)
Byte 1	YYh	Keypad CAN ID 00h: stop all the keypads 15h: stop the keypad with CAN ID = 15h.
Byte 2, 7	00h	Not used

Example:

Direction	Identifier	Format	Message
To Keypad	0	Std	02 15

8. Boot-up service

This service is used to signal that a NMT slave has entered the NMT state Pre-operational.

Identifier	700h + current CAN ID	Default 715h
Byte 0	00h	One data byte is transmitted with value 0.

Example:

Direction	Identifier	Format	Message
From Keypad	715h	Std	00h

The keypad with CAN ID 15h has entered the NMT state Pre-operational.

9. Heartbeat message

The heartbeat mechanism for a CANopen device is established by cyclically transmitting the heartbeat message by the heartbeat producer.

Refer to [Object 1017h](#) for more details.

10. Sync message

This mechanism modifies the PDO operation in the following way: both the RPDOs and TPDOs are stored at the receiving of the 1st SYNC message but, while the RPDOs are always processed with the arrival of next one, the TPDOs are transmitted each n-th time the SYNC message is received depending on the value chosen for transmission type. The structure of the SYNC message is:

Identifier	80h	
-	-	No data byte is transmitted

Refer to Objects [1400-1401-1800h](#) for more details.

PDO messages

PDO (Process Data Object) are fast telegram messages that can simply manage most important functions. There are no answers for this kind of messages. Each PDO message has an equivalent Service Data Object message.

11. Keys state message

The keypad must be activated, see NMT Start CANopen Node message.

- **PKP 3500-MT**

Identifier	180h + current CAN ID	Default 195h
Byte 0	Keys from #1 to #8 K8 K7 K6 K5 – K4 K3 K2 K1	Key state: 1=pressed; 0=released
Byte 1	Keys from #9 to #15 0 K15 K14 K13 – K12 K11 K10 K9	Key state: 1=pressed; 0=released
Byte 2, 3	00h	Not used
Byte 4	XXh	Tick Timer*

Examples:

Direction	Identifier	Format	Message	Key state
From Keypad	195	Std	00 00 00 00 XX	Any Key released
From Keypad	195	Std	01 00 00 00 XX	Only Key #1 pressed
From Keypad	195	Std	10 00 00 00 XX	Only Key #5 pressed
From Keypad	195	Std	00 01 00 00 XX	Only Key #9 pressed
From Keypad	195	Std	11 00 00 00 XX	Keys #1 and #5 pressed
From keypad	195	Std	00 41 00 00 XX	Keys #9 and #15 pressed

*= this hexadecimal value increases each 100ms regardless a key state variation has occurred or not. This parameter can be used to evaluate the time interval elapsed between two consecutive key states through the difference of the related two tick timer values. Since this counter is coded on 1-byte length, the maximum time interval which can be monitored is about 25 seconds.

Keys state message is mapped into:

- Object 2000h sub 1

Refer to the applicable object for more details.

12. Encoder 1 state message

The keypad must be activated, see NMT Start CANopen Node message. This message is sent by the keypad to indicate the state of the encoder 1.

Note: the encoder 1 is identified with the key number 1. See [chapter 2](#) for further details.

The state of the encoder is represented by 3 counter fields:

- The Direction counter (Byte 0) transmits the number of ticks and the direction of the encoder rotation since the last message sent. The MSB of the counter defines the direction.
- The Tick counter (Byte 1 and 2) is a two bytes counter incremented each clockwise tick and decremented each counterclockwise tick.
- The TOP position (Byte 3): when is different from 00h, it is the maximum value the encoder tick counter will count up to. In this case, with each clockwise tick the counter increases until the TOP position is reached; once reached this value, each further tick in this direction does not increase the counter. On the contrary, with each counterclockwise tick the counter decreases from the current value to zero; once reached zero, each further tick in this direction does not change the counter value.

NOTE: the default TOP position value is 08h, but it can be changed by using the [Service Data Object 2000h sub-index 06h](#). In case it is selected the value 00h the maximum encoder tick counter value is 65535.

Identifier	295h (280h + current CAN ID)	Default 295h
Byte 0	X Y Y Y Y Y Y Y b	Encoder Direction counter: X = 0 clockwise, X = 1 counterclockwise. YYYYYYY = number of Ticks. 1 Turn (360° rotation) = 20 Ticks
Byte 1,2	ZZ ZZh	Encoder Tick counter
Byte 3	00h or RRh	TOP position encoder 1
Byte 4,7	00h	Not used

Examples:

Direction	Identifier	Format	Data	Encoder state
From Keypad	295	Std	81 FF FF 00 00 00 00 00	1 tick CCW
From Keypad	295	Std	01 03 00 00 00 00 00 00	3 ticks CW
From Keypad	295	Std	01 01 00 00 00 00 00 00	1 tick CW
From Keypad	295	Std	01 03 00 00 00 00 00 00	3 ticks CW
From Keypad	295	Std	01 02 00 00 00 00 00 00	2 ticks CW
From Keypad	295	Std	01 04 00 05 00 00 00 00	4 ticks CW with 5 as TOP position

Encoder 1 state message is mapped into:

- Object 2000h sub-indices 2-3-6

Refer to the applicable object for more details.

13. Encoder 2 state message

The keypad must be activated, see NMT Start CANopen Node message. This message is sent by the keypad to indicate the state of the encoder 2.

Note: the encoder 2 is identified with the key number 11. See [chapter 2](#) for further details.

The state of the encoder is represented by 3 counter fields:

- The Direction counter (Byte 0) transmits the number of ticks and the direction of the encoder rotation since the last message sent. The MSB of the counter defines the direction.
- The Tick counter (Byte 1 and 2) is a two bytes counter incremented each clockwise tick and decremented each counterclockwise tick.
- The TOP position (Byte 3): when is different from 00h, it is the maximum value the encoder tick counter will count up to. In this case, with each clockwise tick the counter increases until the TOP position is reached; once reached this value, each further tick in this direction does not increase the counter. On the contrary, with each counterclockwise tick the counter decreases from the current value to zero; once reached zero, each further tick in this direction does not change the counter value.

NOTE: the default TOP position value is 08h, but it can be changed by using the [Service Data Object 2000h sub-index 07h](#). In case it is selected the value 00h the maximum encoder tick counter value is 65535.

Identifier	395h (380h + current CAN ID)	Default 395h
Byte 0	X Y Y Y Y Y Y Y b	Encoder Direction counter: X = 0 clockwise, X = 1 counterclockwise. YYYYYYY = number of Ticks. 1 Turn (360° rotation) = 20 Ticks
Byte 1,2	ZZ ZZh	Encoder Tick counter
Byte 3	00h or RRh	TOP position encoder 2
Byte 4,7	00h	Not used

Examples:

Direction	Identifier	Format	Data	Encoder state
From Keypad	395	Std	01 01 00 00 00 00 00 00	1 tick CW
From Keypad	395	Std	81 FE FF 00 00 00 00 00	2 tick CCW
From Keypad	395	Std	81 FD FF 00 00 00 00 00	3 ticks CCW
From Keypad	395	Std	01 0A 00 00 00 00 00 00	10 ticks CW
From Keypad	395	Std	01 10 00 10 00 00 00 00	16 ticks CW with 16 as TOP position

Encoder 2 state message is mapped into:

- Object 2000h subindices 4-5-7

Refer to the applicable object for more details.

14. Analog input message

The keypad must be activated, see NMT Start CANopen Node message.

This message transmits periodically the analog values of each of the four inputs.

The default transmission period is 80 ms, but it is possible to change it by the [Service Data Command 2006h: Set analog input message period](#).

Note: please refer to [chapter 1](#) for the connector pinout.

Note 2: it is possible to connect up to 4 inputs 0-5V. For application examples please refer to [Appendix 2](#).



Warning: the input voltage range is from 0V to 5V. Do not connect input signals beyond these limits. Damage to the device may occur.

Identifier	495h (480h + current CAN ID)	Default 495h
Byte 0	Input 0	YYXXh Vin=(5/500*YYXX _d)
Byte 1		
Byte 2	Input 1	
Byte 3		
Byte 4	Input 2	
Byte 5		
Byte 6	Input 3	
Byte 7		

The minimum detectable voltage value is 10mV.

Analog input value range from 0000 to 01F4 (0 to 500)

Examples:

Direction	Identifier	Format	Message	Data
From Keypad	495	Std	F4 01 00 00 00 00 00 00	Input 0=5V
From Keypad	495	Std	00 00 C8 00 00 00 00 00	Input 1=2V
From Keypad	495	Std	00 00 00 00 2C 01 00 00	Input 2=3V
From Keypad	495	Std	00 00 00 00 00 00 64 00	Input 3=1V

15. Set Key-LED ON message

The keypad must be activated, see NMT Start CANopen Node message.

Note: in case the RPDO message is transmitted periodically to the keypad, to ensure correct processing of the command the period used must be higher than 50ms; a value equal to 100ms is fairly good for most applications.

- **PKP 3500-MT**

Identifier	200h + current CAN ID	Default 215h
Byte 0	R8 R7 R6 R5 – R4 R3 R2 0	Red LED
Byte 1	0 R15 R14 R13 – R12 0 R10 R9	
Byte 2	G8 G7 G6 G5 – G4 G3 G2 0	Green LED
Byte 3	0 G15 G14 G13 – G12 0 G10 G9	
Byte 4	B8 B7 B6 B5 – B4 B3 B2 0	Blue LED
Byte 5	0 B15 B14 B13 – B12 0 B10 B9	
Byte 6,7	00h	Not used

Examples:

Direction	Identifier	Format	Message	LED
To Keypad	215	Std	00 00 00 00 00 00 00 00	Turn OFF all the Key-LED
To Keypad	215	Std	02 00 00 00 00 00 00 00	Only red Key-LED #2 ON
To Keypad	215	Std	00 50 00 00 00 00 00 00	Red Key-LED #14 and #15 ON
To Keypad	215	Std	00 00 06 00 00 00 00 00	Green Key-LED #2, 3 ON
To Keypad	215	Std	00 00 00 70 00 00 00 00	Green Key-LED #13, 14, 15 ON
To Keypad	215	Std	00 00 00 00 10 00 00 00	Blue Key-LED #5 ON
To Keypad	215	Std	04 00 04 00 00 00 00 00	Amber Key-LED #3 ON
To Keypad	215	Std	00 00 00 40 00 40 00 00	Cyan Key-LED #15 ON
To Keypad	215	Std	00 02 00 00 00 02 00 00	Magenta Key-LED #10 ON
To Keypad	215	Std	FE 7B FE 7B FE 7B 00 00	All Key-LED white ON

16. Set Key-LED Blink message

The keypad must be activated, see NMT Start CANopen Node message.

Note: if the blink message is sent when the Key-LED is already ON, the Key-LED blinks in alternate mode.

Note 2: in case the RPDO message is transmitted periodically to the keypad, to ensure correct processing of the command the period used must be higher than 50ms; a value equal to 100ms is fairly good for most applications.

- **PKP 3500-MT**

Identifier	300h + current CAN ID	Default 315h
Byte 0	R8 R7 R6 R5 – R4 R3 R2 0	Red LED
Byte 1	0 R15 R14 R13 – R12 0 R10 R9	
Byte 2	G8 G7 G6 G5 – G4 G3 G2 0	Green LED
Byte 3	0 G15 G14 G13 – G12 0 G10 G9	
Byte 4	B8 B7 B6 B5 – B4 B3 B2 0	Blue LED
Byte 5	0 B15 B14 B13 – B12 0 B10 B9	
Byte 6,7	00h	Not used

Examples:

Direction	Identifier	Format	Message	LED
To Keypad	315	Std	00 00 00 00 00 00 00 00	Turn OFF all the Key-LED
To Keypad	315	Std	00 08 00 00 00 00 00 00	Only red Key-LED #12 blinks
To Keypad	315	Std	06 00 00 00 00 00 00 00	Red Key-LED #2 and #3 blink
To Keypad	315	Std	00 00 20 00 00 00 00 00	Green Key-LED #6 blinks
To Keypad	315	Std	00 00 00 60 00 00 00 00	Green Key-LED #14 and #15 blink
To Keypad	315	Std	00 00 00 00 0C 00 00 00	Blue Key-LED #3 and #4 blink
To Keypad	315	Std	00 00 00 00 00 01 00 00	Blue Key-LED #9 blinks
To Keypad	215 315	Std Std	FE 7B 00 00 00 00 00 00 FE 7B 00 00 FE 7B 00 00	All LED blink red and blue in alternate mode

17. Set LED encoder ON message

The keypad must be activated, see NMT Start CANopen Node message.

See [chapter 2](#) for LED encoder reference.

Note: in case the RPDO message is transmitted periodically to the keypad, to ensure correct processing of the command the period used must be higher than 50ms; a value equal to 100ms is fairly good for most applications.

Identifier	400h + current CAN ID	Default 415h
Byte 0	L8 L7 L6 L5 – L4 L3 L2 L1	LED encoder 1
Byte 1	L16 L15 L14 L13 – L12 L11 L10 L9	
Byte 2	L24 L23 L22 L21 – L20 L19 L18 L17	LED encoder 2
Byte 3	L32 L31 L30 L29 – L28 L27 L26 L25	
Byte 4,7	00h	Not used

Examples:

Direction	Identifier	Format	Message	LED
To Keypad	415	Std	03 00 00 00 00 00 00 00	LEDs 1 and 2 ON
To Keypad	415	Std	00 00 C0 00 00 00 00 00	LEDs 23 and 24 ON

18. Backlight setting

The keypad must be activated, see NMT Start CANopen Node message.

Note: in case a brightness level value greater than 3Fh is set, the command is neglected.

Note 2: if it is selected as brightness level a value inside the valid range and as backlight color a value outside the available range, the backlight is switched on with the current color stored, the default or the last valid temporary one if set.

Note 3: the backlight color setting has temporary effect. If the default setting is desired to change, please refer to the [object 2003h sub-index 04h](#).

Note 4: in case the RPDO message is transmitted periodically to the keypad, to ensure correct processing of the command the period used must be higher than 50ms; a value equal to 100ms is fairly good for most applications.

Identifier	500h + current CAN ID	Default 515h
Byte 0	XXh	Brightness level: 00h-3Fh → 0-100%
Byte 1	YYh	Backlight color:
		01h: red 02h: green 03h: blue 04h: yellow 05h: cyan 06h: violet 07h: white/light blue 08h: amber/orange 09h: yellow/green
Byte 2,7	00h	Not used

Examples:

Direction	Identifier	Format	Message	LED
To Keypad	515	Std	00 00 00 00 00 00 00 00	Turn off the backlight
To Keypad	515	Std	20 01 00 00 00 00 00 00	Backlight active at 50% with red color

SDO Messages:

A SDO (Service Data Object) is providing direct access to object entries of a CANopen device's object dictionary.

19. Object 2000h: Digital input module, keys states

This module contains all the Switch State information.

A one indicates the switch is pressed, a zero indicates the switch is released.

a) Sub 1 - Key state

This module contains all the key state information. A one indicates the key is pressed; a zero indicates the key is not pressed.

Identifier	600h + current CAN ID	Default 615h
Byte 0	40h	Read Device Register
Byte 1	00h	CAN Object 2000h
Byte 2	20h	
Byte 3	01h	Sub index
Byte 4,7	00h	Not used

Examples:

Direction	Identifier	Format	Message	Data
To Keypad	615	Std	40 00 20 01 00 00 00 00	Read keys state
From Keypad	595	Std	4B 00 20 01 00 00 00 00	No Key pressed
			4B 00 20 01 01 00 00 00	Key 1 pressed
			4B 00 20 01 02 00 00 00	Key 2 pressed
			4B 00 20 01 04 00 00 00	Key 3 pressed
			4B 00 20 01 08 00 00 00	Key 4 pressed
			4B 00 20 01 10 00 00 00	Key 5 pressed
			4B 00 20 01 20 00 00 00	Key 6 pressed
			4B 00 20 01 40 00 00 00	Key 7 pressed
			4B 00 20 01 80 00 00 00	Key 8 pressed
			4B 00 20 01 00 01 00 00	Key 9 pressed
			4B 00 20 01 00 02 00 00	Key 10 pressed
			4B 00 20 01 00 04 00 00	Key 11 pressed
			4B 00 20 01 00 08 00 00	Key 12 pressed
			4B 00 20 01 00 10 00 00	Key 13 pressed
			4B 00 20 01 00 20 00 00	Key 14 pressed
			4B 00 20 01 00 40 00 00	Key 15 pressed
			4B 00 20 01 03 00 00 00	Key 1 and 2 pressed
4B 00 20 01 00 42 00 00	Key 10 and 15 pressed			
4B 00 20 01 FF 7F 00 00	All Keys pressed			

b) Sub 2 – Read encoder 1 direction counter

This module contains the Encoder 1 direction counter.

Note: the encoder 1 is identified with the key number 1. See [chapter 2](#) for further details.

Identifier	615h (600h + current CAN ID)	
Byte 0	40h	Read Device Register
Byte 1	00h	CAN Object 2000h
Byte 2	20h	
Byte 3	02h	Sub index
Byte 4,7	00h	Not used

From Keypad:

Identifier	595h (580h + current CAN ID)	
Byte 0	4Fh	
Byte 1	00h	CAN Object 2000h
Byte 2	20h	
Byte 3	02h	Sub index
Byte 4	XXh	Bit 7: encoder direction <ul style="list-style-type: none"> • 0: Clockwise • 1: Counterclockwise Bit 0...6: Number of ticks
Byte 5,7	00h	Not used

The number of ticks is counted from the last encoder state message sent.

The counter is reset after the message is sent out.

Examples:

Direction	Identifier	Format	Message	Data
To Keypad	615	Std	40 00 20 02 00 00 00 00	
From Keypad	595	Std	4F 00 20 02 00 00 00 00	No ticks completed
			4F 00 20 02 01 00 00 00	One tick clockwise
			4F 00 20 02 81 00 00 00	One tick counterclockwise
			4F 00 20 02 02 00 00 00	Two tick clockwise

c) Sub 3 – Read encoder 1 tick counter

The Tick counter is a two bytes counter incremented each clockwise tick and decremented each counterclockwise tick. The following command allows to read the encoder 1 tick counter value.

Note: the encoder 1 is identified with the key number 1. See [chapter 2](#) for further details.

Identifier	615h (600h + current CAN ID)	
Byte 0	40h	Read Device Register
Byte 1	00h	CAN Object 2000h
Byte 2	20h	
Byte 3	03h	Sub index
Byte 4,7	00h	Not used

From Keypad:

Identifier	595h (580h + current CAN ID)	
Byte 0	4Bh	
Byte 1	00h	CAN Object 2000h
Byte 2	20h	
Byte 3	03h	Sub index
Byte 4	YYh	Tick counter
Byte 5	XXh	
Byte 6,7	00h	Not used

d) Sub 4 – Read encoder 2 direction counter

This module contains the Encoder 2 direction counter.

Note: the encoder 2 is identified with the key number 11. See [chapter 2](#) for further details.

Identifier	615h (600h + current CAN ID)	
Byte 0	40h	Read Device Register
Byte 1	00h	CAN Object 2000h
Byte 2	20h	
Byte 3	04h	Sub index
Byte 4,7	00h	Not used

From Keypad:

Identifier	595h (580h + current CAN ID)	
Byte 0	4Fh	
Byte 1	00h	CAN Object 2000h
Byte 2	20h	
Byte 3	04h	Sub index
Byte 4	XXh	Bit 7: encoder direction <ul style="list-style-type: none"> • 0: Clockwise • 1: Counterclockwise Bit 0..6: Number of ticks
Byte 5,7	00h	Not used

The number of ticks is counted from the last encoder state message sent.

The counter is reset after the message is sent out.

Examples:

Direction	Identifier	Format	Message	Data
To Keypad	615	Std	40 00 20 04 00 00 00 00	
From Keypad	595	Std	4F 00 20 04 00 00 00 00	No ticks completed
			4F 00 20 04 01 00 00 00	One tick clockwise
			4F 00 20 04 81 00 00 00	One tick counterclockwise
			4F 00 20 04 02 00 00 00	Two tick clockwise

e) Sub 5 – Read encoder 2 tick counter

The Tick counter is a two bytes counter incremented each clockwise tick and decremented each counterclockwise tick. The following command allows to read the encoder 2 tick counter value.

Note: the encoder 2 is identified with the key number 11. See [chapter 2](#) for further details.

Identifier	615h (600h + current CAN ID)	
Byte 0	40h	Read Device Register
Byte 1	00h	CAN Object 2000h
Byte 2	20h	
Byte 3	05h	Sub index
Byte 4,7	00h	Not used

From Keypad:

Identifier	595h (580h + current CAN ID)	
Byte 0	4Bh	
Byte 1	00h	CAN Object 2000h
Byte 2	20h	
Byte 3	05h	Sub index
Byte 4	YYh	Tick counter
Byte 5	XXh	
Byte 6,7	00h	Not used

f) Sub 6 – Set/read TOP position encoder 1

The following command allows to set and read the TOP position value for the tick counter of encoder 1.

Note: if the value 00h is selected the maximum tick counter value achievable is 65535.

Note 2: the encoder 1 is identified with the key number 1. See [chapter 2](#) for further details.

Identifier	615h (600h + current CAN ID)	
Byte 0	2Fh	Set Device Register
	40h	Read Device Register
Byte 1	00h	CAN Object 2000h
Byte 2	20h	
Byte 3	06h	Sub index
Byte 4	XXh	XXh: 00h: Disabled From 02h (02) to 10h (16)
Byte 5,7	00h	Not used

Examples:

Direction	Identifier	Format	Message	Data
To Keypad	615	Std	2F 00 20 06 08 00 00 00	Set TOP position to 8
From Keypad	595	Std	60 00 20 06 00 00 00 00	Command accepted
To Keypad	615	Std	40 00 20 06 00 00 00 00	Read the set value
From Keypad	595	Std	4F 00 20 06 08 00 00 00	TOP position set to 8

g) Sub 7 – Set/read TOP position encoder 2

The following command allows to set and read the TOP position value for the tick counter of encoder 2.

Note: if the value 00h is selected the maximum tick counter value achievable is 65535.

Note 2: the encoder 2 is identified with the key number 1. See [chapter 2](#) for further details.

Identifier	615h (600h + current CAN ID)	
Byte 0	2Fh	Set Device Register
	40h	Read Device Register
Byte 1	00h	CAN Object 2000h
Byte 2	20h	
Byte 3	07h	Sub index
Byte 4	XXh	XXh: 00h: Disabled From 02h (02) to 10h (16)
Byte 5,7	00h	Not used

Examples:

Direction	Identifier	Format	Message	Data
To Keypad	615	Std	2F 00 20 07 02 00 00 00	Set TOP position to 2
From Keypad	595	Std	60 00 20 07 00 00 00 00	Command accepted
To Keypad	615	Std	40 00 20 07 00 00 00 00	Read the set value
From Keypad	595	Std	4F 00 20 07 02 00 00 00	TOP position set to 2

20. Object 2001h: Digital output module.

This module sets and reads the LED Outputs States. Each bit position represents the corresponding LED. A one indicates the LED is ON a zero indicates the LED is OFF.

a) Set Key-LED ON

Identifier	600h + current CAN ID	Default 615h	
Byte 0	2Bh	Set Device Register	
Byte 1	01h	CAN Object 2001h	
Byte 2	20h		
Byte 3	XXh	XX: Sub index 01h: Red LED 02h: Green LED 03h: Blue LED	
Byte 4	YYh	L8 L7 L6 L5 L4 L3 L2 0	Key-LED position
Byte 5	ZZh	0 L15 L14 L13 L12 0 L10 L9	
Byte 6,7	00h	Not used	

Examples:

Direction	Identifier	Format	Message	Data
To Keypad	615	Std	2B 01 20 01 08 00 00 00	Set red LED #4 ON
From Keypad	595	Std	60 01 20 01 00 00 00 00	Command accepted
To Keypad	615	Std	2B 01 20 03 00 40 00 00	Set blue LED #15 ON
From Keypad	595	Std	60 01 20 03 00 00 00 00	Command accepted

b) Read Key-LED ON

The LED have the same mapping of Set LED ON message

Identifier	600h + current CAN ID	Default 615h	
Byte 0	40h	Read Device Register	
Byte 1	01h	CAN Object 2001h	
Byte 2	20h		
Byte 3	XXh	XX: Sub index 01h: Red LED 02h: Green LED 03h: Blue LED	
Byte 4,7	00h	Not used	

Examples:

Direction	Identifier	Format	Message	Data
To Keypad	615	Std	40 01 20 01 00 00 00 00	Read red LED
From Keypad	595	Std	4B 01 20 01 10 00 00 00	Only red LED #5 ON
To Keypad	615	Std	40 01 20 02 00 00 00 00	Read green LED
From Keypad	595	Std	4B 01 20 02 00 02 00 00	Only green LED #10 ON
To Keypad	615	Std	40 01 20 03 00 00 00 00	Read blue LED
From Keypad	595	Std	4B 01 20 03 00 40 00 00	Only blue LED #15 ON

c) Set LED encoder ON

Identifier	600h + current CAN ID	Default 615h	
Byte 0	23h	Set Device Register	
Byte 1	01h	CAN Object 2001h	
Byte 2	20h		
Byte 3	04h	Sub index: LED encoder ON	
Byte 4	XXh	L8 L7 L6 L5 L4 L3 L2 L1	LED position encoder 1
Byte 5	YYh	L16 L15 L14 L13 L12 L11 L10 L9	
Byte 6	RRh	L24 L23 L22 L21 L20 L19 L18 L17	LED position encoder 2
Byte 7	ZZh	L32 L31 L30 L29 L28 L27 L26 L25	

Examples:

Direction	Identifier	Format	Message	Data
To Keypad	615	Std	23 01 20 04 80 00 00 00	Set LED #8 ON
From Keypad	595	Std	60 01 20 04 00 00 00 00	Command accepted
To Keypad	615	Std	23 01 20 04 00 00 00 40	Set LED #31 ON
From Keypad	595	Std	60 01 20 04 00 00 00 00	Command accepted

d) Read LED encoder ON

The LED have the same mapping of Set LED encoder ON message

Identifier	600h + current CAN ID	Default 615h	
Byte 0	40h	Read Device Register	
Byte 1	01h	CAN Object 2001h	
Byte 2	20h		
Byte 3	04h	Sub index: LED encoder ON	
Byte 4,7	00h	Not used	

Examples:

Direction	Identifier	Format	Message	Data
To Keypad	615	Std	40 01 20 04 00 00 00 00	Read LED encoder ON
From Keypad	595	Std	43 01 20 04 10 00 00 00	Only LED #5 ON
To Keypad	615	Std	40 01 20 04 00 00 00 00	Read LED encoder ON
From Keypad	595	Std	43 01 20 04 00 02 00 00	Only LED #10 ON
To Keypad	615	Std	40 01 20 04 00 00 00 00	Read LED encoder ON
From Keypad	595	Std	43 01 20 04 00 00 00 80	Only LED #32 ON

21. Object 2002h: Digital output module.

This module sets and reads the LED Blink States.

Each bit position represents the corresponding LED. A one indicates the LED is blinking a zero indicates the LED is not blinking. If the blink message is sent when the LED is already ON, the LED blinks in alternate mode.

a) Set Key-LED blink

Identifier	600h + current CAN ID	Default 615h	
Byte 0	2Bh	Set Device Register	
Byte 1	02h	CAN Object 2002h	
Byte 2	20h		
Byte 3	XXh	XX: Sub index 01h: Red LED 02h: Green LED 03h: Blue LED	
Byte 4	YYh	L8 L7 L6 L5 L4 L3 L2 0	Key-LED position
Byte 5	ZZh	0 L15 L14 L13 L12 0 L10 L9	
Byte 6,7	00h	Not used	

Examples:

Direction	Identifier	Format	Message	Data
To Keypad	615	Std	2B 02 20 01 02 00 00 00	Set red LED #2 blink
From Keypad	595	Std	60 02 20 01 00 00 00 00	Command accepted
To Keypad	615	Std	2B 02 20 03 00 01 00 00	Set blue LED #9 blink
From Keypad	595	Std	60 02 20 03 00 00 00 00	Command accepted

b) Read Key-LED blink

Identifier	600h + current CAN ID	Default 615h	
Byte 0	40h	Read Device Register	
Byte 1	02h	CAN Object 2002h	
Byte 2	20h		
Byte 3	XXh	XX: Sub index 01h: Red LED 02h: Green LED 03h: Blue LED	
Byte 4,7	00h	Not used	

Examples:

Direction	Identifier	Format	Message	Data
To Keypad	615	Std	40 02 20 01 00 00 00 00	Read red LED blink
From Keypad	595	Std	4B 02 20 01 FE 7B 00 00	All red LED blink
To Keypad	615	Std	40 02 20 02 00 00 00 00	Read green LED blink
From Keypad	595	Std	4B 02 20 02 02 00 00 00	Only green LED #2 blinks
To Keypad	615	Std	40 02 20 03 00 00 00 00	Read blue LED blink
From Keypad	595	Std	4B 02 20 03 00 03 00 00	Blue LED #9,10 blink

c) Set LED encoder blink

Identifier	600h + current CAN ID	Default 615h	
Byte 0	23h	Set Device Register	
Byte 1	02h	CAN Object 2002h	
Byte 2	20h		
Byte 3	04h	Sub index: Set LED encoder blink	
Byte 4	XXh	L8 L7 L6 L5 L4 L3 L2 L1	LED position encoder 1
Byte 5	YYh	L16 L15 L14 L13 L12 L11 L10 L9	
Byte 6	RRh	L24 L23 L22 L21 L20 L19 L18 L17	LED position encoder 2
Byte 7	ZZh	L32 L31 L30 L29 L28 L27 L26 L25	

Examples:

Direction	Identifier	Format	Message	Data
To Keypad	615	Std	23 02 20 04 02 00 00 00	Set LED #2 ON
From Keypad	595	Std	60 02 20 04 00 00 00 00	Command accepted
To Keypad	615	Std	23 02 20 04 00 00 00 20	Set LED #30 ON
From Keypad	595	Std	60 02 20 04 00 00 00 00	Command accepted

d) Read LED encoder blink

The LED have the same mapping of Set LED encoder ON message

Identifier	600h + current CAN ID	Default 615h
Byte 0	40h	Read Device Register
Byte 1	02h	CAN Object 2002h
Byte 2	20h	
Byte 3	04h	Sub index: Read LED encoder blink
Byte 4,7	00h	Not used

Examples:

Direction	Identifier	Format	Message	Data
To Keypad	615	Std	40 02 20 04 00 00 00 00	Read LED encoder blink
From Keypad	595	Std	43 02 20 04 10 00 00 00	Only LED #5 blinks
To Keypad	615	Std	40 02 20 04 00 00 00 00	Read LED encoder blink
From Keypad	595	Std	43 02 20 04 00 08 00 00	Only LED #12 blinks
To Keypad	615	Std	40 02 20 04 00 00 00 00	Read LED encoder blink
From Keypad	595	Std	43 02 20 04 00 00 00 80	Only LED #32 blinks

22. Object 2003h: Brightness Level

a) LED indicators brightness level:

Set message:

Identifier	615h (600h + current CAN ID)	
Byte 0	2Fh	Set Device Register
Byte 1	03h	CAN Object 2003h
Byte 2	20h	
Byte 3	01h	Sub index
Byte 4	YYh	Intensity 00h-3Fh → min-100%
Byte 5,7	00h	Not used

Read message:

Identifier	615h (600h + current CAN ID)	
Byte 0	40h	Read Device Register
Byte 1	03h	CAN Object 2003h
Byte 2	20h	
Byte 3	01h	Sub index
Byte 4,7	00h	Not used

Example:

Direction	Identifier	Format	Message	Data
To Keypad	615	Std	2F 03 20 01 0D 00 00 00	Brightness = 25%
From Keypad	595	Std	60 03 20 01 00 00 00 00	Command accepted
To Keypad	615	Std	40 03 20 01 00 00 00 00	Read brightness level set
From Keypad	595	Std	4F 03 20 01 0D 00 00 00	Brightness =25%

b) Backlight brightness level

Set message:

Identifier	615h (600h + current CAN ID)	
Byte 0	2Fh	Set Device Register
Byte 1	03h	CAN Object 2003h
Byte 2	20h	
Byte 3	02h	Sub index
Byte 4	XXh	Intensity 00h-3Fh → 0-100%
Byte 5,7	00h	Not used

Read message:

Identifier	615h (600h + current CAN ID)	
Byte 0	40h	Read Device Register
Byte 1	03h	CAN Object 2003h
Byte 2	20h	
Byte 3	02h	Sub index
Byte 4,7	00h	Not used

Example:

Direction	Identifier	Format	Message	Data
To Keypad	615	Std	2F 03 20 02 20 00 00 00	Brightness = 50%
From Keypad	595	Std	60 03 20 02 00 00 00 00	Command accepted
To Keypad	615	Std	40 03 20 02 00 00 00 00	Read brightness level set
From Keypad	595	Std	4F 03 20 02 20 00 00 00	Brightness = 50%

c) Backlight color

Set message:

Identifier	615h (600h + current CAN ID)		
Byte 0	2Fh	Set Device Register	
Byte 1	03h	CAN Object 2003h	
Byte 2	20h		
Byte 3	03h	Sub index	
Byte 4	XXh	Color 01h: red 02h: green 03h: blue 04h: yellow	05h: cyan 06h: violet 07h: white/light blue 08: amber/orange 09: yellow/green
Byte 5,7	00h	Not used	

Read message:

Identifier	615h (600h + current CAN ID)		
Byte 0	40h	Read Device Register	
Byte 1	03h	CAN Object 2003h	
Byte 2	20h		
Byte 3	03h	Sub index	
Byte 4,7	00h	Not used	

Example:

Direction	Identifier	Format	Message	Data
To Keypad	615	Std	2F 03 20 03 06 00 00 00	Violet backlight color
From Keypad	595	Std	60 03 20 03 00 00 00 00	Command accepted
To Keypad	615	Std	40 03 20 03 00 00 00 00	Read backlight color set
From Keypad	595	Std	4F 03 20 03 06 00 00 00	Violet backlight color

d) Default backlight color

Set message:

Identifier	615h (600h + current CAN ID)		
Byte 0	2Fh	Set Device Register	
Byte 1	03h	CAN Object 2003h	
Byte 2	20h		
Byte 3	04h	Sub index	
Byte 4	XXh	Color 01h: red 02h: green 03h: blue 04h: yellow	05h: cyan 06h: violet 07h: white/light blue 08: amber/orange 09: yellow/green
Byte 5,7	00h	Not used	

Read message:

Identifier	615h (600h + current CAN ID)		
Byte 0	40h	Read Device Register	
Byte 1	03h	CAN Object 2003h	
Byte 2	20h		
Byte 3	04h	Sub index	
Byte 4,7	00h	Not used	

Example:

Direction	Identifier	Format	Message	Data
To Keypad	615	Std	2F 03 20 04 04 00 00 00	Yellow backlight color
From Keypad	595	Std	60 03 20 04 00 00 00 00	Command accepted
To Keypad	615	Std	40 03 20 04 00 00 00 00	Read default color set
From Keypad	595	Std	4F 03 20 04 04 00 00 00	Yellow backlight color

e) Default LED indicators brightness level

Set message:

Identifier	615h (600h + current CAN ID)	
Byte 0	2Fh	Set Device Register
Byte 1	03h	CAN Object 2003h
Byte 2	20h	
Byte 3	05h	Sub index
Byte 4	XXh	Intensity 00h-3Fh → min-100%
Byte 5,7	00h	Not used

Read message:

Identifier	615h (600h + current CAN ID)	
Byte 0	40h	Read Device Register
Byte 1	03h	CAN Object 2003h
Byte 2	20h	
Byte 3	05h	Sub index
Byte 4,7	00h	Not used

Example:

Direction	Identifier	Format	Message	Data
To Keypad	615	Std	2F 03 20 05 2D 00 00 00	Brightness = 75%
From Keypad	595	Std	60 03 20 05 00 00 00 00	Command accepted
To Keypad	615	Std	40 03 20 05 00 00 00 00	Read brightness level set
From Keypad	595	Std	4F 03 20 05 2D 00 00 00	Brightness = 75%

f) Default backlight brightness level

Set message:

Identifier	615h (600h + current CAN ID)	
Byte 0	2Fh	Set Device Register
Byte 1	03h	CAN Object 2003h
Byte 2	20h	
Byte 3	06h	Sub index
Byte 4	XXh	Intensity 00h-3Fh → 0-100%
Byte 5,7	00h	Not used

Read message:

Identifier	615h (600h + current CAN ID)	
Byte 0	40h	Read Device Register
Byte 1	03h	CAN Object 2003h
Byte 2	20h	
Byte 3	06h	Sub index
Byte 5,7	00h	Not used

Example:

Direction	Identifier	Format	Message	Data
To Keypad	615	Std	2F 03 20 06 00 00 00 00	Backlight level = 0%
From Keypad	595	Std	60 03 20 06 00 00 00 00	Command accepted
To Keypad	615	Std	40 03 20 06 00 00 00 00	Read backlight level set
From Keypad	595	Std	4F 03 20 06 00 00 00 00	Backlight level = 0%

23. Object 2004h: Read Digital Input 8-bit

This object reads digital input values.

Note: please refer to [chapter 1](#) for the connector pinout.

Note 2: it is possible to connect up to 4 inputs 0-5V. For application examples please refer to [Appendix 2](#).



Warning: the input voltage range is from 0V to 5V. Do not connect input signals beyond these limits. Damage to the device may occur.

Identifier	600h + current CAN ID	Default 615h
Byte 0	40h	Read Device Register
Byte 1	04h	CAN Object 2004h
Byte 2	20h	
Byte 3	00h	Highest sub-index supported
	01h	Read input from IN0 to IN3
Byte 4,7	00h	Not used

From Keypad:

Identifier	595h (580h + current CAN ID)	
Byte 0	4Fh	Response length 1-byte
Byte 1	04h	CAN Object 2004h
Byte 2	20h	

Byte 3	00h	sub-index
Byte 4	01h	Highest sub-index supported
Byte 5,7	00h	Not used

Byte 3	01h	sub-index							
Byte 4	Not used				IN3	IN2	IN1	IN0	Digital input
	-	-	-	-	08h	04h	02h	01h	
Byte 5,7	00h	Not used							

24. Object 2005h: Read Analog Input

This object reads analog input values with 8-bit resolution. 5V=FFh.

Expected value: $(V_{in} \cdot 255/5)_h$

Note: please refer to [chapter 1](#) for the connector pinout.

Note 2: it is possible to connect up to 4 inputs 0-5V. For application examples please refer to [Appendix 2](#).



Warning: the input voltage range is from 0V to 5V. Do not connect input signals beyond these limits. Damage to the device may occur.

Identifier	600h + current CAN ID	Default 615h
Byte 0	40h	Read Device Register
Byte 1	05h	CAN Object 2005h
Byte 2	20h	
Byte 3	00h	Highest sub-index supported
	01h	Input IN0
	02h	Input IN1
	03h	Input IN2
	04h	Input IN3
Byte 4	$(V_{in} \cdot 255/5)_h$	Expected value
Byte 5,7	00h	Not used

Examples:

Direction	Identifier	Format	Message	Data
To Keypad	615	Std	40 05 20 00 00 00 00 00	Read the highest sub-index supported
From Keypad	595	Std	4F 05 20 04 00 00 00 00	04h is the highest sub-index supported
To Keypad	615	Std	40 05 20 01 00 00 00 00	Read Input IN0
From Keypad	595	Std	4F 05 20 01 33 00 00 00	1V
To Keypad	615	Std	40 05 20 02 00 00 00 00	Read Input IN1
From Keypad	595	Std	4F 05 20 02 66 00 00 00	2V
To Keypad	615	Std	40 05 20 03 00 00 00 00	Read Input IN2
From Keypad	595	Std	4F 05 20 03 99 00 00 00	3V
To Keypad	615	Std	40 05 20 04 00 00 00 00	Read Input IN3
From Keypad	595	Std	4F 05 20 04 CC 00 00 00	4V
To Keypad	615	Std	40 05 20 01 00 00 00 00	Read Input IN0
From Keypad	595	Std	4F 05 20 01 FF 00 00 00	5V

26. Object 2006h: Set analog input message period

This configuration message allows to change the default transmission period of the analog input message



Warning: the input voltage range is from 0V to 5V. Do not connect input signals beyond these limits. Damage to the device may occur.

Set message:

Identifier	615h (600h + current CAN ID)	
Byte 0	2Fh	Set Device Register
Byte 1	06h	CAN Object 2006h
Byte 2	20h	
Byte 3	00h	Sub index
Byte 4	XXh	XXh: Period in ms ÷ 10 From 08h (80ms) to C8h (2sec)
Byte 5,7	00h	Not used

Read message:

Identifier	615h (600h + current CAN ID)	
Byte 0	40h	Read Device Register
Byte 1	06h	CAN Object 2006h
Byte 2	20h	
Byte 3	00h	Sub index
Byte 4,7	00h	Not used

Example:

Direction	Identifier	Format	Message	Data
To Keypad	615	Std	2F 06 20 00 64 00 00 00	Period = 1s
From Keypad	595	Std	60 06 20 00 00 00 00 00	Command accepted
To Keypad	615	Std	40 06 20 00 00 00 00 00	Read command set
From Keypad	595	Std	4F 06 20 00 08 00 00 00	Period = 80ms

27. Object 2010h: Baud rate setting

Set message:

Identifier	615h (600h + current CAN ID)	
Byte 0	2Fh	Set Device Register
Byte 1	10h	CAN Object 2010h
Byte 2	20h	
Byte 3	00h	Sub index
Byte 4	00h	1000k
	01h	Reserved (force to 125k)
	02h	500k
	03h	250k
	04h	125k (Default)
	05h	Reserved (force to 125k)
	06h	50k
	07h	20k
Byte 5,7	00h	Not used

Read message:

Identifier	615h (600h + current CAN ID)	
Byte 0	40h	Read Device Register
Byte 1	10h	CAN Object 2010h
Byte 2	20h	
Byte 3	00h	Sub index
Byte 4,7	00h	Not used

Example:

Direction	Identifier	Format	Message	Data
To Keypad	615	Std	2F 10 20 00 02 00 00 00	Baud rate = 500k
From Keypad	595	Std	60 10 20 00 00 00 00 00	Command accepted
To Keypad	615	Std	40 10 20 00 00 00 00 00	Read command set
From Keypad	595	Std	4F 10 20 00 02 00 00 00	Baud rate = 500k

28. Object 2011h: Set Boot-up service

Object 2011h message enables or disables the boot up message sent by the keypad at power up to the CAN network.

Set message:

Identifier	600h + current CAN ID	Default 615h
Byte 0	2Fh	Set Device Register
Byte 1	11h	CAN Object 2011h
Byte 2	20h	
Byte 3	00h	Sub index
Byte 4	XXh	00h: Not active
		01h: Active
Byte 5,7	00h	Not used

Read message:

Identifier	600h + current CAN ID	Default 615h
Byte 0	40h	Read Device Register
Byte 1	11h	CAN Object 2011h
Byte 2	20h	
Byte 3	00h	Sub index
Byte 4,7	00h	Not used

Example:

Direction	Identifier	Format	Message	Data
To Keypad	615	Std	2F 11 20 00 00 00 00 00	Boot-up service not active
From Keypad	595	Std	60 11 20 00 00 00 00 00	Command accepted
To Keypad	615	Std	40 11 20 00 00 00 00 00	Read command set
From Keypad	595	Std	4F 11 20 00 00 00 00 00	Boot-up service not active

29. Object 2012h: Set device active on startup

If keypad is active on startup don't need the Start CANopen command from host.

Set message:

Identifier	600h + current CAN ID	Default 615h
Byte 0	2Fh	Set Device Register
Byte 1	12h	CAN Object 2012h
Byte 2	20h	
Byte 3	00h	Sub index
Byte 4	XXh	00h: Not active
		01h: Active
Byte 5,7	00h	Not used

Read message:

Identifier	600h + current CAN ID	Default 615h
Byte 0	40h	Read Device Register
Byte 1	12h	CAN Object 2012h
Byte 2	20h	
Byte 3	00h	Sub index
Byte 4,7	00h	Not used

Example:

Direction	Identifier	Format	Message	Data
To Keypad	615	Std	2F 12 20 00 01 00 00 00	Device active on startup
From Keypad	595	Std	60 12 20 00 00 00 00 00	Command accepted
To Keypad	615	Std	40 12 20 00 00 00 00 00	Read command set
From Keypad	595	Std	4F 12 20 00 01 00 00 00	Device active on startup

30. Object 2013h: Set CANopen node ID

Note: make sure that when changing node ID to the keypad, no other device on the network has the same address set.

Set message:

Identifier	600h + current CAN ID	Default 615h
Byte 0	2Fh	Set Device Register
Byte 1	13h	CAN Object 2013h
Byte 2	20h	
Byte 3	00h	Sub index
Byte 4	XXh	XX: New node id (01h-7Fh), default 15h
Byte 5,7	00h	Not used

Read message:

Identifier	600h + current CAN ID	Default 615h
Byte 0	40h	Read Device Register
Byte 1	13h	CAN Object 2013h
Byte 2	20h	
Byte 3	00h	Sub index
Byte 4,7	00h	Not used

Example:

Direction	Identifier	Format	Message	Data
To Keypad	615	Std	2F 13 20 00 19 00 00 00	CANopen node ID set to 19h
From Keypad	599	Std	60 13 20 00 00 00 00 00	Command accepted
To Keypad	619	Std	40 13 20 00 00 00 00 00	Read CANopen node ID
From Keypad	599	Std	4F 13 20 00 19 00 00 00	CANopen node ID set to 19h

31. Object 2014h: Set startup LED show

Set message:

Identifier	600h + current CAN ID	Default 615h
Byte 0	2Fh	Set Device Register
Byte 1	14h	CAN Object 2014h
Byte 2	20h	
Byte 3	00h	Sub index
Byte 4	XXh	00h: Disable
		01h: Complete LED Show (default)
		02h: Fast Flash
Byte 5,7	00h	Not used

Read message:

Identifier	600h + current CAN ID	Default 615h
Byte 0	40h	Read Device Register
Byte 1	14h	CAN Object 2014h
Byte 2	20h	
Byte 3	00h	Sub index
Byte 4,7	00h	Not used

Example:

Direction	Identifier	Format	Message	Data
To Keypad	615	Std	2F 14 20 00 00 00 00 00	Startup LED show disabled
From Keypad	595	Std	60 14 20 00 00 00 00 00	Command accepted
To Keypad	615	Std	40 14 20 00 00 00 00 00	Read command set
From Keypad	595	Std	4F 14 20 00 00 00 00 00	Startup LED show disabled

32. Object 2100h: Set DEMO mode

This message enables the Demo mode function. Demo mode is a special feature that consists in different LED states for each button pressing. Refer to the appendix “Demo mode instructions” to try these special features. Disconnect and reconnect the keypad after the sending the message to enter this mode. To exit the Demo mode, disable Demo mode command or enable another command message.

Identifier	600h + current CAN ID	Default 615h
Byte 0	2Fh	Set Device Register
Byte 1	00h	CAN Object 2100h
Byte 2	21h	
Byte 3	00h	Sub index
Byte 4	XXh	00h: Not active
		01h: Active
Byte 5,7	00h	Not used

Example:

Direction	Identifier	Format	Message	Data
To Keypad	615	Std	2F 00 21 00 01 00 00 00	Set DEMO mode Active
From Keypad	595	Std	60 00 21 00 00 00 00 00	Command accepted

33. Object 1016h: Consumer heartbeat time

The consumer heartbeat time object shall indicate the expected heartbeat cycle times. Monitoring of the heartbeat producer shall start after the reception of the first heartbeat.

NOTE 1: the heartbeat consumer time should be greater (typically twice) than the related heartbeat time to be monitored coming from the producer.

NOTE 2: if the keypad does not receive the heartbeat message producer anymore, it turns off all the LEDs eventually ON (both indicators and backlight) and goes to pre-operational state until a new NMT start message is received, even if the producer restarts to transmit the heartbeat.

NOTE 3: if the consumer heartbeat time is set with a value lower than the producer one, the keypad will not be able to change its state from pre-operational to operational.

Identifier	600h + current CAN ID	Default 615h
Byte 0	40h	Read Device Register
	23h	Set device Register
Byte 1	16h	CAN Object 1016h
Byte 2	10h	
Byte 3	ZZh	00h: Highest sub-index supported (read-only) 01h: Sub-index (read/write)
Byte 4	YYh	YYh: Heartbeat time in milliseconds LSByte
Byte 5	XXh	XXh: Heartbeat time in milliseconds MSByte
Byte 6	NNh	Node to be monitored 01h-7Fh (01h default)
Byte 7	00h	Reserved

Heartbeat time: XYYYh (from 000Ah to FFFFh: from 10 to 65535 milliseconds)

When the period is set to 0000h, the consumer heartbeat function is disabled.

Examples:

Direction	Identifier	Format	Message	Data
To Keypad	615	Std	40 16 10 00 00 00 00 00	Read highest sub-index supported
From Keypad	595	Std	4F 16 10 00 01 00 00 00	01h is the highest sub-index supported
To Keypad	615	Std	23 16 10 01 64 00 7E 00	Set heartbeat time consumer = 100ms expected from the node 7Eh
From Keypad	595	Std	60 16 10 01 00 00 00 00	Command accepted
To Keypad	615	Std	23 16 10 01 F4 01 01 00	Set heartbeat time consumer=500ms expected from the node 01h
From Keypad	595	Std	60 16 10 01 00 00 00 00	Command accepted
To Keypad	615	Std	40 16 10 01 00 00 00 00	Read heartbeat consumer time expected from the node 01h
From Keypad	595	Std	43 16 10 01 F4 01 01 00	Heartbeat consumer time set to 500ms

34. Object 1017h: Producer heartbeat time

The producer heartbeat time shall indicate the configured cycle time of the heartbeat.

Identifier	600h + current CAN ID	Default 615h
Byte 0	40h	Read Device Register
	2Bh	Set device Register
Byte 1	17h	CAN Object 1017h
Byte 2	10h	
Byte 3	00h	Sub index
Byte 4	YYh	YYh: Heartbeat time in milliseconds LSBByte
Byte 5	XXh	XXh: Heartbeat time in milliseconds MSByte
Byte 6,7	00h	Not used

Heartbeat time: XYYh (from 000Ah to FEFh: from 10 to 65279 milliseconds).

When the period is set to 0000h, the producer heartbeat function is disabled.

Examples:

Direction	Identifier	Format	Message	Data
To Keypad	615	Std	40 17 10 00 00 00 00 00	Read heartbeat time
From Keypad	595	Std	4B 17 10 00 64 00 00 00	Heartbeat time = 100ms
To Keypad	615	Std	2B 17 10 00 00 00 00 00	Switch off the heartbeat
From Keypad	595	Std	60 17 10 00 00 00 00 00	Command accepted
To Keypad	615	Std	2B 17 10 00 32 00 00 00	Set heartbeat time = 50ms
From Keypad	595	Std	60 17 10 00 00 00 00 00	Command accepted
To Keypad	615	Std	2B 17 10 00 F4 01 00 00	Set heartbeat time = 500ms
From Keypad	595	Std	60 17 10 00 00 00 00 00	Command accepted

Heartbeat message

The heartbeat mechanism for a CANopen device is established by transmitting cyclically the heartbeat message by the heartbeat producer. One or more CANopen devices in the network are aware of this heartbeat message. If the heartbeat cycle fails for the heartbeat producer, the local application on the heartbeat consumer will be informed about that event.

If a CANopen device starts with a value for the heartbeat producer time unequal to 0 the boot-up message is regarded as first heartbeat message.

Identifier	700h + current CAN ID	Default 715h
Byte 0	XXh	XXh: State of heartbeat producer 00h: Boot-up 04h: Stop 05h: Operational 7Fh: Pre-operational

Example:

Direction	Identifier	Format	Message	Data
From Keypad	715h	Std	00h	Boot up
From Keypad	715h	Std	7Fh	Pre-operational
To Keypad	00h	Std	01h 15h	Start keypad with CAN ID 15h
From Keypad	715h	Std	05h	Operational

35. Object 1000h: Device Type

Identifier	600h + current CAN ID	Default 615h
Byte 0	40h	Read Device Register
Byte 1	00h	CAN Object 1000h
Byte 2	10h	
Byte 3, 7	00h	Not used

Example:

Direction	Identifier	Format	Data
To Keypad	615	Std	40 00 10 00 00 00 00 00
From Keypad	595	Std	43 00 10 00 91 01 0B 00

Device profile number 0xB0191h.

36. Object 1001h: Error Register

This object is not yet implemented in the device.

37. Object 1008h: Manufacturer Device Name

Identifier	600h + current CAN ID	Default 615h
Byte 0	40h	Read Device Register
Byte 1	08h	CAN Object 1008h
Byte 2	10h	
Byte 3, 7	00h	Not used

1° additional byte

Identifier	600h + current CAN ID	Default 615h
Byte 0	60h	Read Device Register Next Byte
Byte 1, 7	00h	Not used

2° additional byte

Identifier	600h + current CAN ID	Default 615h
Byte 0	70h	Read Device Register Next Byte
Byte 1, 7	00h	Not used

Example:

Direction	Identifier	Format	Message	Data
To Keypad	615	Std	40 08 10 00 00 00 00 00	
From Keypad	595	Std	41 08 10 00 0B 00 00 00	
To Keypad	615	Std	60 00 00 00 00 00 00 00	
From Keypad	595	Std	00 42 6C 69 6E 6B 4D 61	BlinkMa
To Keypad	615	Std	70 00 00 00 00 00 00 00	
From Keypad	595	Std	17 72 69 6E 65 00 00 00	rine

Manufacturer Device Name: BlinkMarine

The first byte of the last data message replied is 17h.

38. Object 1009h: Manufacturer Hardware Revision

Identifier	600h + current CAN ID	Default 615h
Byte 0	40h	Read Device Register
Byte 1	09h	CAN Object 1009h
Byte 2	10h	
Byte 3, 7	00h	Not used

Example:

Direction	Identifier	Format	Message	Data
To Keypad	615	Std	40 09 10 00 00 00 00 00	
From Keypad	595	Std	43 09 10 00 56 5F 30 30	V_00

Manufacturer Hardware Revision: V_00

39. Object 100Ah: Manufacturer Firmware Revision

Identifier	600h + current CAN ID	Default 615h
Byte 0	40h	Read Device Register
Byte 1	0Ah	CAN Object 100Ah
Byte 2	10h	
Byte 3, 7	00h	Not used

Example:

Direction	Identifier	Format	Message	Data
To Keypad	615	Std	40 0A 10 00 00 00 00 00	
From Keypad	595	Std	43 0A 10 00 31 2E 30 30	1.00

Manufacturer Firmware Revision: 1.00

40. Object 100Bh: Model ID

Identifier	600h + current CAN ID	Default 615h
Byte 0	40h	Read Device Register
Byte 1	0Bh	CAN Object 100Bh
Byte 2	10h	
Byte 3, 7	00h	Not used

1° additional byte

Identifier	600h + current CAN ID	Default 615h
Byte 0	60h	Read Device Register second byte
Byte 1, 7	00h	Not used

2° additional byte

Identifier	600h + current CAN ID	Default 615h
Byte 0	70h	Read Device Register third byte
Byte 1, 7	00h	Not used

Example:

Direction	Identifier	Format	Message	Data
To Keypad	615	Std	40 0B 10 00 00 00 00 00	
From Keypad	595	Std	41 0B 10 00 09 00 00 00	
To Keypad	615	Std	60 00 00 00 00 00 00 00	
From Keypad	595	Std	00 50 4B 50 33 35 30 30	PKP3500
To Keypad	615	Std	70 00 00 00 00 00 00 00	
From Keypad	595	Std	1B 4D 54 00 00 00 00 00	MT

Model ID: PKP3500-MT

The first byte of the last data message replied is 1Bh.

41. Object 1011h: Restore default parameters

With this object the default values of parameters according to the communication profile, device profile, and application profile are restored. This procedure shall only be executed when the specific signature "load" is written to the sub-index 01h. When the message shown in the following table is transmitted, the default values shall be restored after the keypad is reset.

Identifier	615h (600h + current CAN ID)	
Byte 0	40h	Read Device Register
	23h	Set Device Register
Byte 1	11h	CAN Object 1011h
Byte 2	10h	
Byte 3	00h	Highest sub-index supported
	01h	Restore all parameters
Byte 4	6Ch	Character 1 "l"
Byte 5	6Fh	Character 2 "o"
Byte 6	61h	Character 3 "a"
Byte 7	64h	Character 4 "d"

Examples:

Direction	Identifier	Format	Message	Data
To Keypad	615	Std	40 11 10 00 00 00 00 00	Read highest sub-index
From Keypad	595	Std	4F 11 10 00 01 00 00 00	1
To Keypad	615	Std	23 11 10 01 6C 6F 61 64	'load'
From Keypad	595	Std	43 11 10 01 00 00 00 00	Command accepted

42. Object 1018h: Identity Data

Identifier	615h (600h + current CAN ID)	
Byte 0	40h	Read Device Register
Byte 1	18h	CAN Object 1018h
Byte 2	10h	
Byte 3	00h	Number of mapped objects
	01h	Vendor Id
	04h	Serial number
Byte 4,7	00h	Not used

Examples:

Direction	Identifier	Format	Message	Data
To Keypad	615	Std	40 18 10 00 00 00 00 00	
From Keypad	595	Std	4F 18 10 00 04 00 00 00	4
To Keypad	615	Std	40 18 10 01 00 00 00 00	
From Keypad	595	Std	43 18 10 01 E2 03 00 00	000003E2h

Blink Marine Vendor Id: 000003E2h

43. Object 1400h: Receive PDO Communication Parm 0

Describes the Receive Parameters and sets the transmission type for the Key-LED state PDO Message.

Identifier	615h (600h + current CAN ID)	
Byte 0	40h	Read Device Register
	2Fh	Set Device Register
Byte 1	00h	CAN Object 1400h
Byte 2	14h	
Byte 3	00h	Number of mapped objects
	01h	COB Id
	02h	Transmission Type
Byte 4	XXh	Transmission Type (to be used only in set mode): 00h-F0h: synchronous FEh: event-driven
Byte 5,7	00h	Not used

Examples:

Direction	Identifier	Format	Message	Data
To Keypad	615	Std	40 00 14 00 00 00 00 00	
From Keypad	595	Std	4F 00 14 00 02 00 00 00	2
To Keypad	615	Std	40 00 14 01 00 00 00 00	
From Keypad	595	Std	43 00 14 01 15 02 00 00	0000 0215h
To Keypad	615	Std	40 00 14 02 00 00 00 00	
From Keypad	595	Std	4F 00 14 02 FE 00 00 00	FEh
To Keypad	615	Std	2F 00 14 02 01 00 00 00	Set Synchronous RPDO 0
From Keypad	595	Std	60 00 14 02 00 00 00 00	ACK
To Keypad	80	Std	-	SYNC message received
To Keypad	215	Std	01 00 00 00 00 00 00 00	Request LED 1 red ON: the data are buffered
To Keypad	80	Std	-	SYNC message received and message 215 processed

Receive PDO communication Parm 0:

- Number of mapped objects: 2;
- COB id: 0000 0200h + NODE ID;
- Transmission Type: synchronous or event-driven.

44. Object 1401h: Receive PDO communication Parm 1

Describes the Receive Parameters and sets the transmission type for the Key-LED blink PDO Message.

Identifier	615h (600h + current CAN ID)	
Byte 0	40h	Read Device Register
	2Fh	Set Device Register
Byte 1	01h	CAN Object 1401h
Byte 2	14h	
Byte 3	00h	Number of mapped objects
	01h	COB Id
	02h	Transmission Type
Byte 4	XXh	Transmission Type (to be used only in set mode): 00h-F0h: synchronous FEh: event-driven
Byte 5,7	00h	Not used

Examples:

Direction	Identifier	Format	Message	Data
To Keypad	615	Std	40 01 14 00 00 00 00 00	
From Keypad	595	Std	4F 01 14 00 02 00 00 00	2
To Keypad	615	Std	40 01 14 01 00 00 00 00	
From Keypad	595	Std	43 01 14 01 15 03 00 00	0000 0315h
To Keypad	615	Std	40 01 14 02 00 00 00 00	
From Keypad	595	Std	4F 01 14 02 FE 00 00 00	FEh
To Keypad	615	Std	2F 01 14 02 00 00 00 00	Set Synchronous RPDO 1
From Keypad	595	Std	60 01 14 02 00 00 00 00	ACK
To Keypad	80	Std	-	SYNC message received
To Keypad	315	Std	00 01 00 00 00 00 00 00	Request LED 1 green blinking: the data are buffered
To Keypad	80	Std	-	SYNC message received and message 315 processed

Receive PDO communication Parm 1:

- Number of mapped objects: 2;
- COB id: 0000 0300h + NODE ID;
- Transmission Type: synchronous or event-driven.

45. Object 1402h: Receive PDO communication Parm 2

Describes the Receive Parameters for Indicator LED encoder ON PDO Message.

Identifier	615h (600h + current CAN ID)	
Byte 0	40h	Read Device Register
	2Fh	
Byte 1	02h	CAN Object 1402h
Byte 2	14h	
Byte 3	00h	Number of mapped objects
	01h	COB Id
	02h	Transmission Type
Byte 4,7	00h	Not used

Examples:

Direction	Identifier	Format	Message	Data
To Keypad	615	Std	40 02 14 00 00 00 00 00	
From Keypad	595	Std	4F 02 14 00 02 00 00 00	2
To Keypad	615	Std	40 02 14 01 00 00 00 00	
From Keypad	595	Std	43 02 14 01 15 04 00 00	0000 415h
To Keypad	615	Std	40 02 14 02 00 00 00 00	
From Keypad	595	Std	4F 02 14 02 FE 00 00 00	FEh

Receive PDO communication Parm 2:

- Number of mapped objects: 2;
- COB id: 0000 0400h + NODE ID;
- Transmission Type: event-driven.

46. Object 1403h: Receive PDO communication Parm 3

Describes the Receive Parameters for backlight setting PDO message.

Identifier	615h (600h + current CAN ID)	
Byte 0	40h	Read Device Register
Byte 1	03h	CAN Object 1403h
Byte 2	14h	
Byte 3	00h	Highest sub-index supported
	01h	COB Id
	02h	Transmission Type
Byte 4,7	00h	Not used

Examples:

Direction	Identifier	Format	Message	Data
To Keypad	615	Std	40 03 14 00 00 00 00 00	
From Keypad	595	Std	4F 03 14 00 02 00 00 00	2
To Keypad	615	Std	40 03 14 01 00 00 00 00	
From Keypad	595	Std	43 03 14 01 15 05 00 00	0000 0515h
To Keypad	615	Std	40 03 14 02 00 00 00 00	
From Keypad	595	Std	4F 03 14 02 FE 00 00 00	FEh

Receive PDO communication Parm 3:

- Number of mapped objects: 2;
- COB id: 0000 0500h + NODE ID;
- Transmission Type: event-driven.

47. Object 1600h: Receive PDO mapping Parameter 0

Describes the mapping of Key-LED state PDO Message.

Identifier	615h (600h + current CAN ID)	
Byte 0	40h	Read Device Register
Byte 1	00h	CAN Object 1600h
Byte 2	16h	
Byte 3	00h	Number of mapped objects
	01h	PDO Mapping Entry 1
	02h	PDO Mapping Entry 2
	03h	PDO Mapping Entry 3
Byte 4,7	00h	Not used

Examples:

Direction	Identifier	Format	Message	Data
To Keypad	615	Std	40 00 16 00 00 00 00 00	
From Keypad	595	Std	4F 00 16 00 03 00 00 00	3
To Keypad	615	Std	40 00 16 01 00 00 00 00	
From Keypad	595	Std	43 00 16 01 10 01 01 20	2001 01 10
To Keypad	615	Std	40 00 16 02 00 00 00 00	
From Keypad	595	Std	43 00 16 02 10 02 01 20	2001 02 10
To Keypad	615	Std	40 00 16 03 00 00 00 00	
From Keypad	595	Std	43 00 16 03 10 03 01 20	2001 03 10

Receive PDO mapping Parameter 0:

- Number of mapped objects: 3;
- Set LED red: Object 2001h, Sub index 01h, Length 10h;
- Set LED green: Object 2001h, Sub index 02h, Length 10h;
- Set LED blue: Object 2001h, Sub index 03h, Length 10h.

48. Object 1601h: Receive PDO mapping Parameter 1

Describes the mapping of Key-LED blink state PDO Message.

Identifier	615h (600h + current CAN ID)	
Byte 0	40h	Read Device Register
Byte 1	01h	CAN Object 1601h
Byte 2	16h	
Byte 3	00h	Number of mapped objects
	01h	PDO Mapping Entry 1
	02h	PDO Mapping Entry 2
	03h	PDO Mapping Entry 3
Byte 4,7	00h	Not used

Examples:

Direction	Identifier	Format	Message	Data
To Keypad	615	Std	40 01 16 00 00 00 00 00	
From Keypad	595	Std	4F 01 16 00 03 00 00 00	3
To Keypad	615	Std	40 01 16 01 00 00 00 00	
From Keypad	595	Std	43 01 16 01 10 01 02 20	2002 01 10
To Keypad	615	Std	40 01 16 02 00 00 00 00	
From Keypad	595	Std	43 01 16 02 10 02 02 20	2002 02 10
To Keypad	615	Std	40 01 16 03 00 00 00 00	
From Keypad	595	Std	43 01 16 03 10 03 02 20	2002 03 10

Receive PDO mapping Parameter 1:

- Number of mapped objects: 3;
- Set LED red blink: Object 2002h, Sub index 01h, Length 10h;
- Set LED green blink: Object 2002h, Sub index 02h, Length 10h;
- Set LED blue blink: Object 2002h, Sub index 03h, Length 10h.

49. Object 1602h: Receive PDO mapping Parameter 2

Describes the mapping of LED encoder PDO Message.

Identifier	615h (600h + current CAN ID)	
Byte 0	40h	Read Device Register
Byte 1	02h	CAN Object 1602h
Byte 2	16h	
Byte 3	00h	Number of mapped objects
	01h	PDO Mapping Entry 1
Byte 4,7	00h	Not used

Examples:

Direction	Identifier	Format	Message	Data
To Keypad	615	Std	40 02 16 00 00 00 00 00	
From Keypad	595	Std	4F 02 16 00 01 00 00 00	1
To Keypad	615	Std	40 02 16 01 00 00 00 00	
From Keypad	595	Std	43 02 16 01 20 04 01 20	2001 04 20

Receive PDO mapping Parameter 2:

- Number of mapped objects: 1;
- Set Indicator LED brightness: Object 2001h, Sub index 04h, Length 20h.

50. Object 1603h: Receive PDO mapping Parameter 3

Describes the mapping of backlight setting PDO Message.

Identifier	615h (600h + current CAN ID)	
Byte 0	40h	Read Device Register
Byte 1	03h	CAN Object 1603h
Byte 2	16h	
Byte 3	00h	Number of mapped objects
	01h	PDO Mapping Entry 1
	02h	PDO Mapping Entry 2
Byte 4,7	00h	Not used

Examples:

Direction	Identifier	Format	Message	Data
To Keypad	615	Std	40 03 16 00 00 00 00 00	
From Keypad	595	Std	4F 03 16 00 02 00 00 00	2
To Keypad	615	Std	40 03 16 01 00 00 00 00	
From Keypad	595	Std	43 03 16 01 08 02 03 20	2003 02 08
To Keypad	615	Std	40 03 16 02 00 00 00 00	
From Keypad	595	Std	43 03 16 02 08 03 03 20	2003 03 08

Receive PDO mapping Parameter 3:

- Number of mapped objects: 2;
- Backlight brightness level: Object 2003h, Sub index 02h, Length 08h;
- Backlight color: Object 2003h, Sub-index 03h, Length 08h.

51. Object 1800h:

a) Transmit PDO Communication Parm 0

Describes the Transmission Parameters and sets the transmission type for the Key state PDO Message.

Identifier	615h (600h + current CAN ID)	
Byte 0	40h	Read Device Register
	2Fh	Set Device Register
Byte 1	00h	CAN Object 1800h
Byte 2	18h	
Byte 3	00h	Highest sub-index supported
	01h	COB Id
	02h	Transmission Type
	05h	Event Timer (Periodic transmission time)
Byte 4	XXh	Transmission Type (to be used only in set mode): 01h: synchronous (cyclic every SYNC) 02h: synchronous (cyclic every 2 nd SYNC) 03h: synchronous (cyclic every 3 rd SYNC) 04h: synchronous (cyclic every 4 th SYNC) F0h: synchronous (cyclic every 240 th SYNC) FEh: event-driven (default)
Byte 5,7	00h	Not used

Examples:

Direction	Identifier	Format	Message	Data
To Keypad	615	Std	40 00 18 00 00 00 00 00	
From Keypad	595	Std	4F 00 18 00 05 00 00 00	5
To Keypad	615	Std	40 00 18 01 00 00 00 00	
From Keypad	595	Std	43 00 18 01 95 01 00 00	0000 0195h
To Keypad	615	Std	40 00 18 02 00 00 00 00	
From Keypad	595	Std	4F 00 18 02 FE 00 00 00	FEh: event-driven type
To Keypad	615	Std	40 00 18 05 00 00 00 00	
From Keypad	595	Std	4B 00 18 05 00 00 00 00	0000h: Periodic transmission disabled.
To Keypad	615	Std	2F 00 18 02 01 00 00 00	Set the Synchronous transmission (cyclic every SYNC).
From Keypad	595	Std	60 00 18 02 00 00 00 00	ACK
To Keypad	80	Std	-	SYNC message received
Key #1 pressed No message on the CAN bus				
From Keypad	195	Std	00 00 00 00 XX	Key status sent/ Read key status
To Keypad	80	Std	-	SYNC message received
From Keypad	195	Std	01 00 00 00 XX	Key status sent/ Read key status

Transmit PDO communication Parm 0:

- Highest sub-index supported: 5;
- Address base: 195h= 180h+ NODE ID;
- Transmission Type: synchronous or event-driven;
- Periodic Transmission timer: XXYY in milliseconds, 0 = OFF.

- **Set periodic state transmission**

Identifier	600h + current CAN ID	Default 615h
Byte 0	2Bh	Set device register
Byte 1	00h	CAN Object 1800h
Byte 2	18h	
Byte 3	05h	Sub index
Byte 4	YYh	YYh: Periodic transmission timer in milliseconds LSByte
Byte 5	XXh	XXh: Periodic transmission timer in milliseconds MSByte
Byte 6, 7	00h	Not used

Periodic Transmission timer: XYYh (from 000Ah to FEFh: from 10 to 65279 milliseconds).

Examples:

Direction	Identifier	Format	Message	Data
To Keypad	615	Std	2B 00 18 05 00 00 00 00	Switch off the periodic state transmission
From Keypad	595	Std	60 00 18 05 00 00 00 00	Command accepted
To Keypad	615	Std	2B 00 18 05 32 00 00 00	Set period = 50ms
From Keypad	595	Std	60 00 18 05 00 00 00 00	Command accepted
To Keypad	615	Std	2B 00 18 05 F4 01 00 00	Set period = 500ms
From Keypad	595	Std	60 00 18 05 00 00 00 00	Command accepted

52. Object 1801h:

Transmit PDO Communication Parm 1

Describes the Transmission Parameters for the Encoder 1 state PDO Message.

Identifier	615h (600h + current CAN ID)	
Byte 0	40h	Read Device Register
Byte 1	01h	CAN Object 1801h
Byte 2	18h	
Byte 3	00h	Highest sub-index supported
	01h	COB Id
	02h	Transmission Type
	05h	Event Timer (Periodic transmission time)
Byte 4,7	00h	Not used

Examples:

Direction	Identifier	Format	Message	Data
To Keypad	615	Std	40 01 18 00 00 00 00 00	
From Keypad	595	Std	4F 01 18 00 05 00 00 00	5
To Keypad	615	Std	40 01 18 01 00 00 00 00	
From Keypad	595	Std	43 01 18 01 95 02 00 00	0000 0295h
To Keypad	615	Std	40 01 18 02 00 00 00 00	
From Keypad	595	Std	4F 01 18 02 FE 00 00 00	FEh: event-driven type
To Keypad	615	Std	40 01 18 05 00 00 00 00	
From Keypad	595	Std	4B 01 18 05 00 00 00 00	0000h: Periodic transmission disabled.

Transmit PDO communication Parm 0:

- Highest sub-index supported: 5;
- Address base: 295h= 280h+ NODE ID;
- Transmission Type: event-driven or periodic (see [Set periodic state transmission](#) for further details).

53. Object 1802h:

Transmit PDO Communication Parm 2

Describes the Transmission Parameters for the Encoder 2 state PDO Message.

Identifier	615h (600h + current CAN ID)	
Byte 0	40h	Read Device Register
Byte 1	02h	CAN Object 1802h
Byte 2	18h	
Byte 3	00h	Highest sub-index supported
	01h	COB Id
	02h	Transmission Type
	05h	Event Timer (Periodic transmission time)
Byte 4,7	00h	Not used

Examples:

Direction	Identifier	Format	Message	Data
To Keypad	615	Std	40 02 18 00 00 00 00 00	
From Keypad	595	Std	4F 02 18 00 05 00 00 00	5
To Keypad	615	Std	40 02 18 01 00 00 00 00	
From Keypad	595	Std	43 02 18 01 95 03 00 00	0000 0395h
To Keypad	615	Std	40 02 18 02 00 00 00 00	
From Keypad	595	Std	4F 02 18 02 FE 00 00 00	FEh: event-driven type
To Keypad	615	Std	40 02 18 05 00 00 00 00	
From Keypad	595	Std	4B 02 18 05 00 00 00 00	0000h: Periodic transmission disabled.

Transmit PDO communication Parm 0:

- Highest sub-index supported: 5;
- Address base: 395h= 380h+ NODE ID;
- Transmission Type: event-driven or periodic (see [Set periodic state transmission](#) for further details).

54. Object 1803h:

Transmit PDO Communication Parm 2

Describes the Transmission Parameters for the analog input state PDO Message.

Identifier	615h (600h + current CAN ID)	
Byte 0	40h	Read Device Register
Byte 1	03h	CAN Object 1803h
Byte 2	18h	
Byte 3	00h	Highest sub-index supported
	01h	COB Id
	02h	Transmission Type
Byte 4,7	00h	Not used

Examples:

Direction	Identifier	Format	Message	Data
To Keypad	615	Std	40 03 18 00 00 00 00 00	
From Keypad	595	Std	4F 03 18 00 02 00 00 00	2
To Keypad	615	Std	40 03 18 01 00 00 00 00	
From Keypad	595	Std	43 03 18 01 95 04 00 00	0000 0495h
To Keypad	615	Std	40 03 18 02 00 00 00 00	
From Keypad	595	Std	4F 03 18 02 XX 00 00 00	Periodic transmission each XX*ms

Transmit PDO communication Parm 0:

- Highest sub-index supported: 2;
- Address base: 495h= 480h+ NODE ID;
- Transmission Type: periodic only. *NOTE: the XXh period depends on the value set by the [Service Data Object 2006h: Set analog input message period](#).

55. Object 1A00h Transmit PDO Mapping Parameter 0

Describes the mapping of Key state PDO Message.

Identifier	615h (600h + current CAN ID)	
Byte 0	40h	Read Device Register
Byte 1	00h	CAN Object 1A00h
Byte 2	1Ah	
Byte 3	00h	Number of mapped objects
	01h	PDO Mapping Entry 1
Byte 4,7	00h	Not used

Examples:

Direction	Identifier	Format	Message	Data
To Keypad	615	Std	40 00 1A 00 00 00 00 00	
From Keypad	595	Std	4F 00 1A 00 01 00 00 00	1
To Keypad	615	Std	40 00 1A 01 00 00 00 00	
From Keypad	595	Std	43 00 1A 01 10 01 00 20	2000 01 10

Transmit PDO Mapping Parameter:

- Number of mapped objects: 1;
- Switch state: Object 2000h, Sub index 01h, Length 10h.

56. Object 1A01h Transmit PDO Mapping Parameter 1

Describes the mapping of Encoder 1 state PDO Message.

Identifier	615h (600h + current CAN ID)	
Byte 0	40h	Read Device Register
Byte 1	01h	CAN Object 1A01h
Byte 2	1Ah	
Byte 3	00h	Number of mapped objects
	01h	PDO Mapping Entry 2
	02h	PDO Mapping Entry 3
	03h	PDO Mapping Entry 6
Byte 4,7	00h	Not used

Examples:

Direction	Identifier	Format	Message	Data
To Keypad	615	Std	40 01 1A 00 00 00 00 00	
From Keypad	595	Std	4F 01 1A 00 03 00 00 00	3
To Keypad	615	Std	40 01 1A 01 00 00 00 00	
From Keypad	595	Std	43 01 1A 01 08 02 00 20	2000 02 08
To Keypad	615	Std	40 01 1A 02 00 00 00 00	
From Keypad	595	Std	43 01 1A 02 10 03 00 20	2000 03 10
To Keypad	615	Std	40 01 1A 03 00 00 00 00	
From Keypad	595	Std	43 01 1A 03 08 06 00 20	2000 06 08

Transmit PDO Mapping Parameter:

- Number of mapped objects: 3;
- Read encoder 1 direction counter: Object 2000h, Sub index 02h, Length 08h;
- Read encoder 1 tick counter: Object 2000h, Sub index 03h, Length 10h;
- TOP position encoder 1: Object 2000h, Sub index 06h, Length 08h.

57. Object 1A02h Transmit PDO Mapping Parameter 2

Describes the mapping of Encoder 2 state PDO Message.

Identifier	615h (600h + current CAN ID)	
Byte 0	40h	Read Device Register
Byte 1	02h	CAN Object 1A02h
Byte 2	1Ah	
Byte 3	00h	Number of mapped objects
	01h	PDO Mapping Entry 4
	02h	PDO Mapping Entry 5
	03h	PDO Mapping Entry 7
Byte 4,7	00h	Not used

Examples:

Direction	Identifier	Format	Message	Data
To Keypad	615	Std	40 02 1A 00 00 00 00 00	
From Keypad	595	Std	4F 02 1A 00 03 00 00 00	3
To Keypad	615	Std	40 02 1A 01 00 00 00 00	
From Keypad	595	Std	43 02 1A 01 08 04 00 20	2000 04 08
To Keypad	615	Std	40 02 1A 02 00 00 00 00	
From Keypad	595	Std	43 02 1A 02 10 05 00 20	2000 05 10
To Keypad	615	Std	40 02 1A 03 00 00 00 00	
From Keypad	595	Std	43 02 1A 03 08 07 00 20	2000 07 08

Transmit PDO Mapping Parameter:

- Number of mapped objects: 3;
- Read encoder 2 direction counter: Object 2000h, Sub index 04h, Length 08h;
- Read encoder 2 tick counter: Object 2000h, Sub index 05h, Length 10h;
- TOP position encoder 2: Object 2000h, Sub index 07h, Length 08h.

58. Object 2200h: Serial number string

Identifier	600h + current CAN ID	Default 615h
Byte 0	40h	Read Device Register
Byte 1	00h	CAN Object 2200h
Byte 2	22h	
Byte 3,7	00h	Not used

1° additional byte

Identifier	600h + current CAN ID	Default 615h
Byte 0	60h	Read Device Register second byte
Byte 1, 7	00h	Not used

2° additional byte

Identifier	600h + current CAN ID	Default 615h
Byte 0	70h	Read Device Register third byte
Byte 1, 7	00h	Not used

Example:

Direction	Identifier	Format	Message	Data
To Keypad	615	Std	40 00 22 00 00 00 00 00	
From Keypad	595	Std	41 00 22 00 08 00 00 00	
To Keypad	615	Std	60 00 00 00 00 00 00 00	
From Keypad	595	Std	00 46 46 46 46 46 46 46	FFFFFF
To Keypad	615	Std	70 00 00 00 00 00 00 00	
From Keypad	595	Std	1D 46 00 00 00 00 00 00	F

Serial number: ascii FFFFFFFF

The first byte of the last data message replied is 1Dh.

APPENDIX: DEMO Mode instructions

In DEMO Mode you can try the following functions by pressing keys on the PKP3500-MT.

Entering this mode, you turn the LED indicators on with red color (opening feature); each time you press the key 1 you can change the color of the indicators with the following sequence:

1. Red;
2. Green;
3. Blue;
4. Yellow;
5. Cyan;
6. Magenta;
7. White/light blue;
8. Amber;
9. Yellow/green;
10. OFF.

Holding down the key 2, you can increase LED brightness level.

Holding down the key 3, you can decrease LED brightness level.

If you press the key 4, there are different steps in this sequence:

1. Complete LED show of all colors;
2. Backlight active with keys on in sequence (it is possible to change the color of LED indicators by pressing key 1 and the color of the backlight by pressing key 5);
3. Alternate blinking of LED keys number 8 with red color; 2-9 with amber color; 3-10 with yellow color; 4 with green color; 5-12 with cyan color; 6-13 with white color; 7-14 with blue color; 15 with yellow/green color.
4. Return to the opening feature.

If the encoders are turned, the LED indicators around switch:

- ON rotating clockwise;
- OFF rotating counterclockwise.

In the case you press the other keys there are no events.

APPENDIX 2: Input application examples

This chapter shows a list of possible input applications.

NOTE: the power supply and ground available on the Input Signal Connector must be used for the external connected devices.

1. Switch high side on input 3:

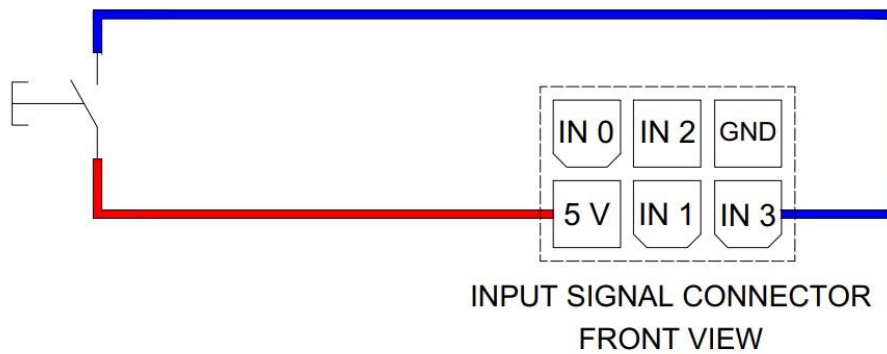

2. Switch low side on inputs 0, 1, 2, and 3:

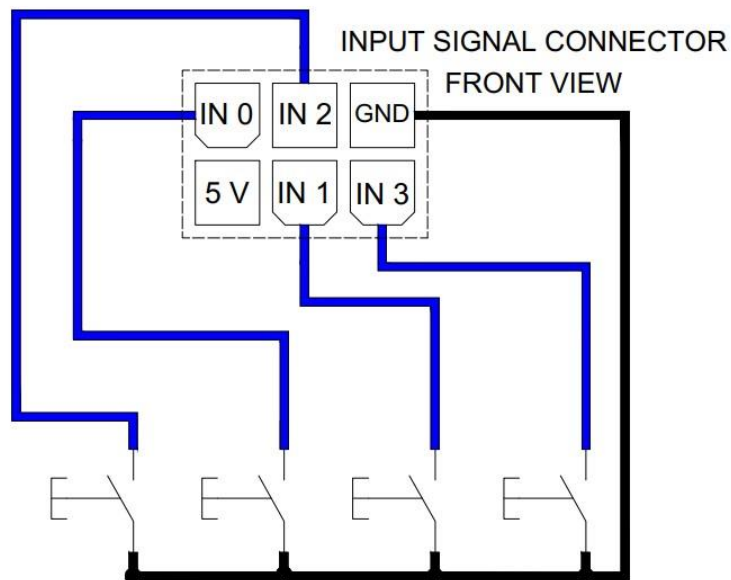

3. Digital active signal on input 2:

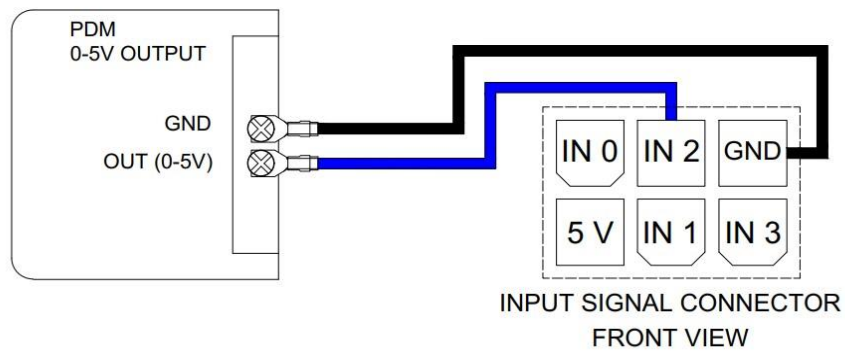

4. Active analog sensor:

- Pressure transducer – signal on input 0

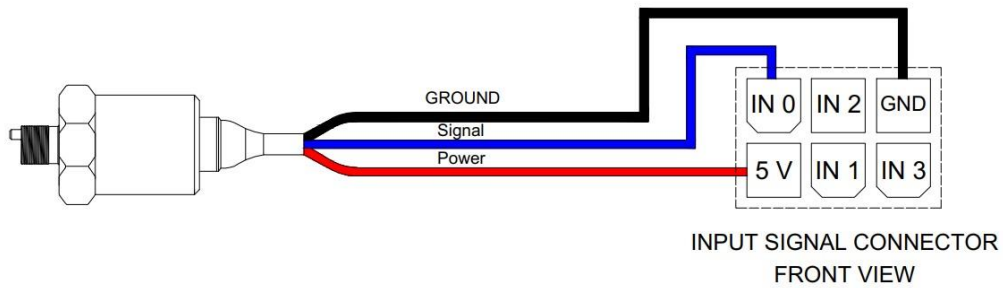

- Hall effect position sensor – signal on input 0

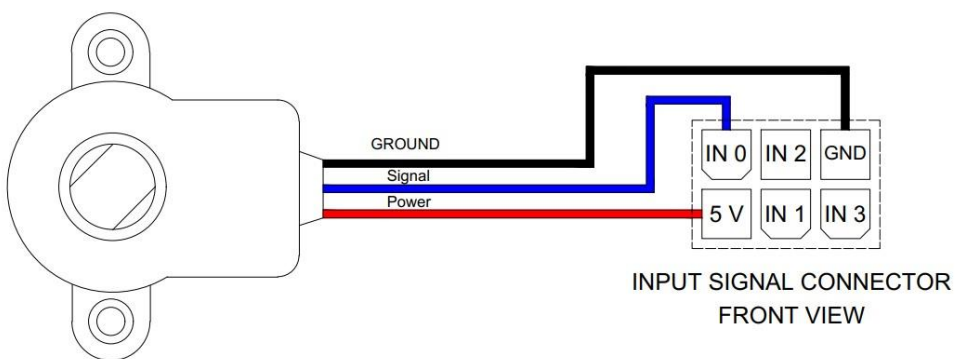

5. The use of passive sensors such as NTC thermistors, potentiometers, and all kind of variable resistors is not recommended!

59. Revision history

Date	Manual Revision	Comment
18/11/2022	1.0	First release