

Summary:

1. How to connect the wires:.....	5
2. Reference.....	6
3. Mounting instructions	7
4. Default settings.....	9
CANopen Messages Structure	10
NMT MESSAGES.....	11
5. Start CANopen node (keypad activation message)	11
6. Enter pre-operational	11
7. Reset CANopen node.....	11
8. Stop CANopen node	12
9. Boot-up service.....	12
10. Heartbeat message.....	12
11. Sync message.....	12
PDO messages	13
12. Keys state message.....	13
• Racepad.....	13
13. Encoders 1-2 state message	14
14. Encoders 3-4 state message	15
15. Analog input message.....	16
16. Set Key and Ring encoder LED ON message	17
• Racepad.....	17
17. Set Key and Ring encoder LED Blink message	18
• Racepad.....	18
18. Set Central and Encoder LED ON message	19
19. Backlight message.....	20
SDO Messages:	21
20. Object 2000h: Digital input module, keys states.....	21
a) Sub 1 – Key state	21
b) Sub 2 – Read encoder 1 direction counter.....	22
c) Sub 3 – Read encoder 1 tick counter	23
d) Sub 4 – Set/read TOP position encoder 1	23
e) Sub 5 – Read encoder 2 direction counter.....	24
f) Sub 6 – Read encoder 2 tick counter	25
g) Sub 7 – Set/read TOP position encoder 2	25
h) Sub 8 – Read encoder 3 direction counter.....	26

i) Sub 9 – Read encoder 3 tick counter	27
j) Sub 10 – Set/read TOP position encoder 3	27
k) Sub 11 – Read encoder 4 direction counter.....	28
l) Sub 12 – Read encoder 4 tick counter	29
m) Sub 13 – Set/read TOP position encoder 4	29
21. Object 2001h: Digital output module.....	30
a) Set Key-LED ON	30
b) Read Key-LED ON.....	30
c) Set Encoder LED ON.....	31
d) Read Encoder LED ON.....	31
e) Set Central LED ON	32
f) Read Central LED ON	32
g) Set Ring encoder LED ON.....	33
h) Read Ring encoder LED ON.....	33
22. Object 2002h: Digital output module.....	34
a) Set Key-LED blink	34
b) Read Key-LED blink	34
c) Set Encoder LED blink	35
d) Read Encoder LED blink	35
e) Set Central LED blink.....	36
f) Read Central LED blink.....	36
g) Set Ring encoder LED blink	37
h) Read Ring encoder LED blink	37
23. Object 2003h: Brightness Level	38
a) Default Key-LED indicators brightness level	38
b) Default Key-LED backlight brightness level.....	39
c) Default Key-LED backlight color	40
d) Default Ring LED indicators brightness level.....	41
e) Default Ring LED backlight brightness level	41
f) Default Central and encoder LED indicators brightness level.....	42
g) Default logo LED backlight brightness level	42
24. Object 2004h: Read Digital Input 8-bit	43
25. Object 2005h: Read Analog Input.....	44
26. Object 2006h: Set analog input message period.....	45
26. Object 2007h: Enable/Disable backlight.....	46
26. Object 2008h: Enable/Disable Encoder state message	47
27. Object 2010h: Baud rate setting.....	48
28. Object 2011h: Set Boot-up service	49
29. Object 2012h: Set device active on startup.....	50

30.	Object 2013h: Set CANopen node ID.....	51
31.	Object 2014h: Set startup LED show	52
32.	Object 2100h: Set DEMO mode.....	53
33.	Object 1016h: Consumer heartbeat time.....	54
34.	Object 1017h: Producer heartbeat time	55
	Heartbeat message.....	55
35.	Object 1000h: Device Type.....	56
36.	Object 1001h: Error Register	56
37.	Object 1008h: Manufacturer Device Name.....	56
38.	Object 1009h: Manufacturer Hardware Revision.....	57
39.	Object 100Ah: Manufacturer Firmware Revision	57
40.	Object 100Bh: Model ID	58
41.	Object 1011h: Restore default parameters.....	58
42.	Object 1018h: Identity Data	59
43.	Object 1400h: Receive PDO Communication Parm 0.....	60
44.	Object 1401h: Receive PDO communication Parm 1	61
45.	Object 1402h: Receive PDO communication Parm 2	62
46.	Object 1403h: Receive PDO communication Parm 3	63
47.	Object 1600h: Receive PDO mapping Parameter 0.....	64
48.	Object 1601h: Receive PDO mapping Parameter 1.....	65
49.	Object 1602h: Receive PDO mapping Parameter 2.....	66
50.	Object 1603h: Receive PDO mapping Parameter 3.....	66
51.	Object 1800h:	67
	a) Transmit PDO Communication Parm 0	67
	• Set periodic state transmission.....	68
52.	Object 1801h:	69
	Transmit PDO Communication Parm 1.....	69
53.	Object 1802h:	70
	Transmit PDO Communication Parm 2.....	70
54.	Object 1803h:	71
	Transmit PDO Communication Parm 3.....	71
55.	Object 1A00h Transmit PDO Mapping Parameter 0.....	72
56.	Object 1A01h Transmit PDO Mapping Parameter 1.....	73
57.	Object 1A02h Transmit PDO Mapping Parameter 2.....	74
58.	Object 2200h: Serial number string.....	75
	APPENDIX: DEMO Mode instructions.....	76
	APPENDIX 2: Input application examples.....	77
59.	Revision history.....	79

NOTE: this document complies with the following CAN in Automation (CiA) specifications:

- 301 (CANopen application layer and communication profile)
- 401 (Device profile for generic I/O modules)

1. How to connect the wires:



Power Supply Connector		
Manufacturer	TE Connectivity / Deutsch	Amphenol
Connector p/n	DTM04-4P	ATM04-4P
Mating Connector		
Connector p/n	DTM06-4S	ATM06-4S
Wedglock p/n	WM4S	AWM4S
Terminals	0462-201-20141	AT62-201-20141

PIN	COLOUR	FUNCTION
1	Blue	CAN L
2	White	CAN H
3	Black	Negative battery
4	Red	Vbatt. (12-24V)



Input Signal Connector		
Connector p/n: Molex 39-013-069		
PIN	COLOUR	FUNCTION
1	Red	Power +5V
2	Yellow	IN0
3	Blue	IN1
4	Grey	IN2
5	Green	IN3
6	Black	GND
Mating Connector		
Connector p/n: Molex 39-01-2065		
Terminals p/n: Molex 39-00-0039		



Warning: the input voltage range is from 0V to 5V. Do not connect input signals beyond these limits. Damage to the device may occur.

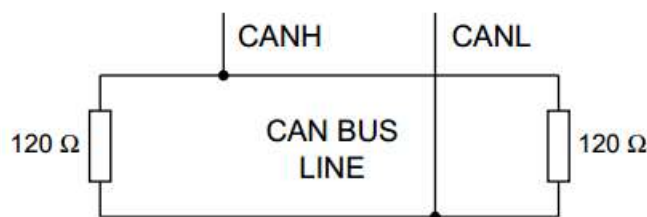

Each end of the CAN bus is terminated with 120Ω resistors in compliance with the standard to minimize signal reflections on the bus. You may need to place a 120Ω resistor between CAN-L and CAN-H.



Warning: to avoid breakage do not tighten the backshell nuts with a torque exceeding 1.8 Nm!

2. Reference

Front view.

Racepad

KEY:

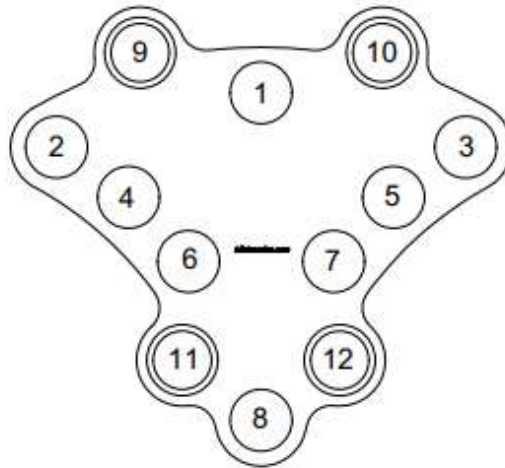

LED:

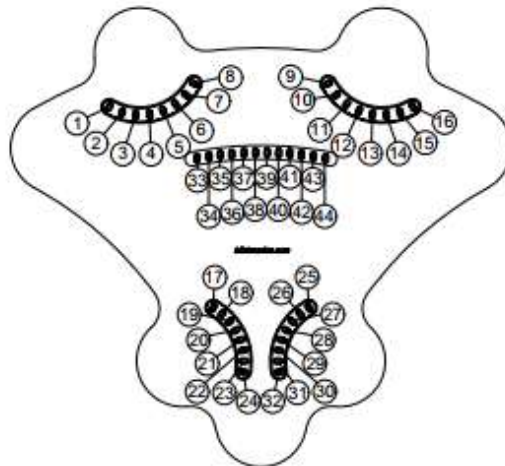

3. Mounting instructions

1: fasten the metal plate to the steering wheel by clamping the six screws.



2: assemble the Racepad to the steering wheel by fastening the M5 screws along the four holes of the metal plate and the backshell. Bend the wires to the preferred side to simplify the installation on the steering wheel.

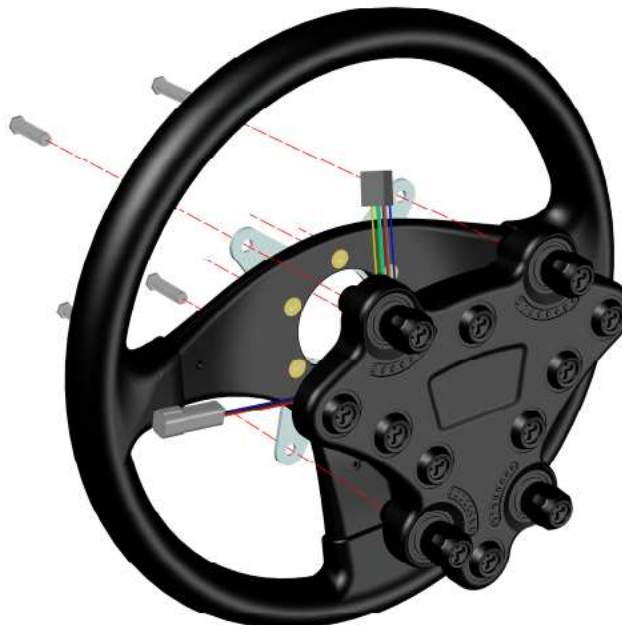

3: plug the connectors to complete the installation.



4. Default settings

Setting	Default state or level	How to change
Baud Rate	125 kbit/s	Object 2010h
CANopen Node ID	15h	Object 2013h
Device active on startup	Not active	Object 2012h
Default Key-LED indicators brightness level	3Fh (100%)	Object 2003h-Sub 1
Default Key-LED backlight brightness level	00h (OFF)	Object 2003h-Sub 2
Default Key-LED backlight color	Amber	Object 2003h-Sub 3
Default Central and encoder LED indicators brightness level	FFh (100%)	Object 2003-Sub 6
Default Ring LED indicators brightness level	FFh (100%)	Object 2003h-Sub 4
Default Ring backlight brightness level	00h (OFF)	Object 2003h-Sub 5
Default Logo backlight brightness level	7Fh (50%)	Object 2003h-Sub 7
Default backlight state	Enabled	Object 2007h
Startup LED Light Show	Complete LED Sequence	Object 2014h
Periodic key-state transmission	Disabled	Object 1800h
DEMO mode	Disabled	Object 2100h
Heartbeat producer	Disabled	Object 1017h
Heartbeat consumer	Disabled	Object 1016h
Boot-up service	Active	Object 2011h
RPDO 200h transmission type	Event-driven	Object 1400h
RPDO 300h transmission type	Event-driven	Object 1401h
RPDO 400h transmission type	Event-driven	Object 1402h
TPDO 180h transmission type	Event-driven	Object 1800h
TPDO 480h transmission type	Periodic (80ms)	Object 2006h
Encoder state message transmission	Enabled	Object 2008h
TOP position encoder 1	08h	Object 2000h-Sub 4
TOP position encoder 2		Object 2000h-Sub 7
TOP position encoder 3		Object 2000h-Sub 10
TOP position encoder 4		Object 2000h-Sub 13

CANopen Messages Structure

All the data type used are unsigned integer and the syntax is specified in the following table:

octet number	1.	2.	3.	4.	5.	6.	7.	8.
UNSIGNED8	b7..b0							
UNSIGNED16	b7..b0	b15..b8						
UNSIGNED24	b7..b0	b15..b8	b23..b16					
UNSIGNED32	b7..b0	b15..b8	b23..b16	b31..b24				
UNSIGNED40	b7..b0	b15..b8	b23..b16	b31..b24	b39..b32			
UNSIGNED48	b7..b0	b15..b8	b23..b16	b31..b24	b39..b32	b47..b40		
UNSIGNED56	b7..b0	b15..b8	b23..b16	b31..b24	b39..b32	b47..b40	b55..b48	
UNSIGNED64	b7..b0	b15..b8	b23..b16	b31..b24	b39..b32	b47..b40	b55..b48	b63..b56

NMT MESSAGES

The Network Management messages follow a master-slave structure. Through NMT services, CANopen devices are initialized, started, reset, or stopped. All CANopen devices are regarded as NMT slaves. NMT messages have CAN-ID always equal to 00h.

00h	1-byte command specifier	1-byte NODE-ID	6 bytes not used
-----	--------------------------	----------------	------------------

PDO MESSAGES

PDO are fast telegram messages that can simply manage the most important functions. All PDOs have an equivalent SDO message. There are no answers for this type of messages. PDO messages have identifiers from 180h to 57Fh.

Identifier	8-byte data
------------	-------------

SDO MESSAGES

SDO are more complex messages that completely manage all the functions of the Keypad.

SDO messages have identifiers from 580h to 67Fh and always expect an answer or an acknowledge reply.

Identifier	Command byte	2-byte index	1-byte sub index	4-byte data
------------	--------------	--------------	------------------	-------------

Identifier: The messages to the Keypad shall have 600h+current CAN ID identifier.

The messages from the Keypad have 580h+ current CAN ID identifier.

Command byte:

40h: request to read a register	60h: write acknowledge
43h: response with 4-byte data	23h: request to write 4-byte data
4Fh: response with 1-byte data	2Fh: request to write 1-byte data
4Bh: response with 2-byte data	2Bh: request to write 2-byte data
80h: error response	

Every answer has index and sub index echo.

The error responses have the byte data containing the abort codes.

Abort codes implemented:

0602 0000h:	Object does not exist in the object dictionary
0609 0011h:	Sub-index does not exist
0609 0030h:	Invalid value for parameter
0601 0002h:	Attempt to write a read only object
0607 0010h:	Data length too long
0601 0001h:	Attempt to read a write only object
0100 0405h:	Invalid value for command byte

NMT MESSAGES

The Network Management messages follow a master-slave structure. Through NMT services, CANopen devices are initialized, started, reset or stopped.
NMT messages have CAN-ID always equal to 00h.

5. Start CANopen node (keypad activation message)

Identifier	00h	
Byte 0	01h	Start CANopen node
Byte 1	XXh	Keypad CAN ID 00h: start all the keypads 15h: start the keypad with CAN ID = 15h.
Byte 2, 7	00h	Not used

Example:

Direction	Identifier	Format	Message
To Keypad	0	Std	01 15

6. Enter pre-operational

Identifier	00h	
Byte 0	80h	Enter pre-operational
Byte 1	XXh	Keypad CAN ID 00h: enter all the keypads 15h: enter the keypad with CAN ID = 15h.
Byte 2, 7	00h	Not used

Example:

Direction	Identifier	Format	Message
To Keypad	0	Std	80 15

7. Reset CANopen node

Identifier	00h	
Byte 0	81h	Reset CANopen node
Byte 1	XXh	Keypad CAN ID 00h: reset all the keypads 15h: reset the keypad with CAN ID = 15h.
Byte 2, 7	00h	Not used

Example:

Direction	Identifier	Format	Message
To Keypad	0	Std	81 15

8. Stop CANopen node

Identifier	00h	
Byte 0	XXh	02h: Stop CANopen node
		00h: Stop CANopen node (old PKP sw compatibility)
Byte 1	YYh	Keypad CAN ID 00h: stop all the keypads 15h: stop the keypad with CAN ID = 15h.
Byte 2, 7	00h	Not used

Example:

Direction	Identifier	Format	Message
To Keypad	0	Std	02 15

9. Boot-up service

This service is used to signal that a NMT slave has entered the NMT state Pre-operational.

Identifier	700h + current CAN ID	Default 715h
Byte 0	00h	One data byte is transmitted with value 0.

Example:

Direction	Identifier	Format	Message
From Keypad	715h	Std	00h

The keypad with CAN ID 15h has entered the NMT state Pre-operational.

10. Heartbeat message

The heartbeat mechanism for a CANopen device is established by cyclically transmitting the heartbeat message by the heartbeat producer.

Refer to [Object 1017h](#) for more details.

11. Sync message

This mechanism modifies the PDO operation in the following way: both the RPDOs and TPDOs are stored at the receiving of the 1st SYNC message but, while the RPDOs are always processed with the arrival of next one, the TPDOs are transmitted each n-th time the SYNC message is received depending on the value chosen for transmission type. The structure of the SYNC message is:

Identifier	80h	
-	-	No data byte is transmitted

Refer to Objects [1400-1401-1800h](#) for more details.

PDO messages

PDO (Process Data Object) are fast telegram messages that can simply manage most important functions. There are no answers for this kind of messages. Each PDO message has an equivalent Service Data Object message.

12. Keys state message

The keypad must be activated, see NMT Start CANopen Node message.

- **Racepad**

Identifier	180h + current CAN ID	Default 195h
Byte 0	Keys from #1 to #8 K8 K7 K6 K5 – K4 K3 K2 K1	Key state: 1=pressed; 0=released
Byte 1	Keys from #9 to #12 0 0 0 0 – K12 K11 K10 K9	Key state: 1=pressed; 0=released
Byte 2, 3	00h	Not used
Byte 4	XXh	Tick Timer*

Examples:

Direction	Identifier	Format	Message	Key state
From Keypad	195	Std	00 00 00 00 XX	Any Key released
From Keypad	195	Std	01 00 00 00 XX	Only Key #1 pressed
From Keypad	195	Std	02 00 00 00 XX	Only Key #2 pressed
From Keypad	195	Std	00 02 00 00 XX	Only Key #10 pressed
From Keypad	195	Std	00 04 00 00 XX	Only Key #11 pressed
From keypad	195	Std	FF 0F 00 00 XX	All keys pressed

*= this hexadecimal value increases each 100ms regardless a key state variation has occurred or not. This parameter can be used to evaluate the time interval elapsed between two consecutive key states through the difference of the related two tick timer values. Since this counter is coded on 1-byte length, the maximum time interval which can be monitored is about 25 seconds.

Keys state message is mapped into:

- Object 2000h sub 1

Refer to the applicable object for more details.

13. Encoders 1-2 state message

The keypad must be activated, see NMT Start CANopen Node message. This message is sent by the keypad to indicate the state of the encoders 1 and 2.

Note: The Encoders 1-2 are identified respectively with the key numbers 9-10. See [chapter 2](#) for further details.

The state of each encoder is represented by 3 counter fields:

- The Direction counter (Bytes 0 and 4) transmits the number of ticks and the direction of the encoder rotation since the last message sent. The MSB of the counter defines the direction.
- The Tick counter (Bytes 1-2 and 5-6) is a two bytes counter incremented each clockwise tick and decremented each counterclockwise tick.
- The TOP position (Bytes 3 and 7): when is different from 00h, it is the maximum value the encoder tick counter will count up to. In this case, with each clockwise tick the counter increases until the TOP position is reached; once reached this value, each further tick in this direction does not increase the counter. On the contrary, with each counterclockwise tick the counter decreases from the current value to zero; once reached zero, each further tick in this direction does not change the counter value.

NOTE: the default TOP position value is 08h, but it can be changed by using respectively the [Service Data Object 2000h sub-index 06h](#) for encoder 1 and the [Service Data Object 2000h sub-index 07h](#) for encoder 2. In case it is selected the value 00h the maximum encoder tick counter value is 65535.

NOTE 2: it is possible to disable the transmission of this message by the configuration [object 2008h: Enable/Disable Encoder state message](#).

Identifier	295h (280h + current CAN ID)	Default 295h
Byte 0	X Y Y Y Y Y Y Y _b	Encoder 1 Direction counter: X = 0 clockwise, X = 1 counterclockwise. YYYYYYY = number of Ticks. 1 Turn (360° rotation) = 16 Ticks
Byte 1,2	ZZ ZZh	Encoder 1 Tick counter
Byte 3	00h or RRh	TOP position encoder 1
Byte 4	L M M M M M M M _b	Encoder 2 Direction counter: L = 0 clockwise, L = 1 counterclockwise. MMMMMMM = number of Ticks. 1 Turn (360° rotation) = 16 Ticks
Byte 5,6	NN NNh	Encoder 2 Tick counter
Byte 7	00h or SSh	TOP position encoder 2

Examples:

Direction	Identifier	Format	Data	Encoders state
From Keypad	295	Std	81 FF FF 00 00 00 00 00	1 tick CCW (encoder 1)
From Keypad	295	Std	01 03 00 04 00 00 00 00	2 ticks CW with 4 as TOP position (encoder 1)
From Keypad	295	Std	00 00 00 00 81 FE FF 00	2 ticks CCW (encoder 2)
From Keypad	295	Std	00 00 00 00 01 01 00 03	1 tick CW with 3 as TOP position (encoder 2)

Encoders 1-2 state message is mapped into:

- Object 2000h sub-indices 2-3-6-7

Refer to the applicable object for more details.

14. Encoders 3-4 state message

The keypad must be activated, see NMT Start CANopen Node message. This message is sent by the keypad to indicate the state of the encoders 3 and 4.

Note: The Encoders 3-4 are identified respectively with the key numbers 11-12. See [chapter 2](#) for further details.

The state of each encoder is represented by 3 counter fields:

- The Direction counter (Bytes 0 and 4) transmits the number of ticks and the direction of the encoder rotation since the last message sent. The MSB of the counter defines the direction.
- The Tick counter (Bytes 1-2 and 5-6) is a two bytes counter incremented each clockwise tick and decremented each counterclockwise tick.
- The TOP position (Bytes 3 and 7): when is different from 00h, it is the maximum value the encoder tick counter will count up to. In this case, with each clockwise tick the counter increases until the TOP position is reached; once reached this value, each further tick in this direction does not increase the counter. On the contrary, with each counterclockwise tick the counter decreases from the current value to zero; once reached zero, each further tick in this direction does not change the counter value.

NOTE: the default TOP position value is 08h, but it can be changed by using respectively the [Service Data Object 2000h sub-index 08h for encoder 3](#) and [Service Data Object 2000h sub-index 09h for encoder 4](#). In case it is selected the value 00h the maximum encoder tick counter value is 65535.

NOTE 2: it is possible to disable the transmission of this message by the configuration [object 2008h: Enable/Disable Encoder state message](#).

Identifier	395h (380h + current CAN ID)	Default 395h
Byte 0	X Y Y Y Y Y Y Y _b	Encoder 3 Direction counter: X = 0 clockwise, X = 1 counterclockwise. YYYYYYY = number of Ticks. 1 Turn (360° rotation) = 16 Ticks
Byte 1,2	ZZ ZZh	Encoder 3 Tick counter
Byte 3	00h or RRh	TOP position encoder 3
Byte 4	L M M M M M M M _b	Encoder 4 Direction counter: L = 0 clockwise, L = 1 counterclockwise. MMMMMMM = number of Ticks. 1 Turn (360° rotation) = 16 Ticks
Byte 5,6	NN NNh	Encoder 4 Tick counter
Byte 7	00h or SSh	TOP position encoder 4

Examples:

Direction	Identifier	Format	Data	Encoders state
From Keypad	395	Std	81 FC FF 00 00 00 00 00	3 ticks CCW (encoder 3)
From Keypad	395	Std	01 05 00 0A 00 00 00 00	5 ticks CW with 10 as TOP position (encoder 3)
From Keypad	395	Std	00 00 00 00 81 FA FF 00	5 ticks CCW (encoder 4)
From Keypad	395	Std	00 00 00 00 01 01 00 02	1 tick CW with 2 as TOP position (encoder 4)

Encoders 3-4 state message is mapped into:

- Object 2000h subindices 4-5-8-9

Refer to the applicable object for more details.

15. Analog input message

The keypad must be activated, see NMT Start CANopen Node message.

This message transmits periodically the analog values of each of the four inputs.

The default transmission period is 80 ms, but it is possible to change it by the [Service Data Command 2006h: Set analog input message period](#).

Note: please refer to [chapter 1](#) for the connector pinout.

Note 2: it is possible to connect up to 4 inputs 0-5V. For application examples please refer to [Appendix 2](#).



Warning: the input voltage range is from 0V to 5V. Do not connect input signals beyond these limits. Damage to the device may occur.

Identifier	495h (480h + current CAN ID)	Default 495h
Byte 0	Input 0	YYXXh $V_{in}=(5/500*YYXX_d)$
Byte 1		
Byte 2	Input 1	
Byte 3		
Byte 4	Input 2	
Byte 5		
Byte 6	Input 3	
Byte 7		

The minimum detectable voltage value is 10mV.

Analog input value range from 0000 to 01F4 (0 to 500)

Examples:

Direction	Identifier	Format	Message	Data
From Keypad	495	Std	F4 01 00 00 00 00 00 00	Input 0=5V
From Keypad	495	Std	00 00 C8 00 00 00 00 00	Input 1=2V
From Keypad	495	Std	00 00 00 00 2C 01 00 00	Input 2=3V
From Keypad	495	Std	00 00 00 00 00 00 64 00	Input 3=1V

16. Set Key and Ring encoder LED ON message

This message allows to switch on/off the key-LED indicators and the ring LEDs around each of the four encoders.

Note: it is possible to adjust the brightness level of the Key-LED indicators by the [object 2003h sub-index 01h](#).

Note 2: it is possible to adjust the brightness level of the Ring encoder LED indicators by the [object 2003h sub-index 04h](#).

The keypad must be activated, see NMT Start CANopen Node message.

Note: in case the RPDO message is transmitted periodically to the keypad, to ensure correct processing of the command the period used must be higher than 50ms; a value equal to 100ms is fairly good for most applications.

• Racepad

Identifier	200h + current CAN ID	Default 215h
Byte 0	R8 R7 R6 R5 – R4 R3 R2 R1	Red LED
Byte 1	G8 G7 G6 G5 – G4 G3 G2 G1	Green LED
Byte 2	B8 B7 B6 B5 – B4 B3 B2 B1	Blue LED
Byte 3	0 0 0 0 – E4 E3 E2 E1	E1: ring LEDs around encoder 1 E2: ring LEDs around encoder 2 E3: ring LEDs around encoder 3 E4: ring LEDs around encoder 4
Byte 4,7	00h	Not used

Examples:

Direction	Identifier	Format	Message	LED
To Keypad	215	Std	00 00 00 00 00 00 00 00	Turn OFF all the Key-LED
To Keypad	215	Std	01 00 00 00 00 00 00 00	Red Key-LED #1 ON
To Keypad	215	Std	80 00 00 00 00 00 00 00	Red Key-LED #8 ON
To Keypad	215	Std	00 0C 00 00 00 00 00 00	Green Key-LED #3, 4 ON
To Keypad	215	Std	00 80 00 00 00 00 00 00	Green Key-LED #8 ON
To Keypad	215	Std	00 00 60 00 00 00 00 00	Blue Key-LED #6,7 ON
To Keypad	215	Std	02 02 00 00 00 00 00 00	Amber Key-LED #2 ON
To Keypad	215	Std	00 80 80 00 00 00 00 00	Cyan Key-LED #8 ON
To Keypad	215	Std	01 00 01 00 00 00 00 00	Magenta Key-LED #1 ON
To Keypad	215	Std	FF FF FF 00 00 00 00 00	All Key-LED white ON
To Keypad	215	Std	00 00 00 01 00 00 00 00	Ring LEDs around encoder 1 ON

17. Set Key and Ring encoder LED Blink message

By this message the key-LED indicators and the ring LEDs around each of the four encoders blink. The keypad must be activated, see NMT Start CANopen Node message.

Note: it is possible to adjust the brightness level of the Key-LED indicators by the [object 2003h sub-index 01h](#).

Note 2: it is possible to adjust the brightness level of the Ring encoder LED indicators by the [object 2003h sub-index 04h](#).

Note 3: if the blink message is sent when the Key-LED is already ON, the Key-LED blinks in alternate mode; this feature is not available for ring encoder LED.

Note 4: in case the RPDO message is transmitted periodically to the keypad, to ensure correct processing of the command the period used must be higher than 50ms; a value equal to 100ms is fairly good for most applications.

- **Racepad**

Identifier	300h + current CAN ID	Default 315h
Byte 0	R8 R7 R6 R5 – R4 R3 R2 R1	Red LED
Byte 1	G8 G7 G6 G5 – G4 G3 G2 G1	Green LED
Byte 2	B8 B7 B6 B5 – B4 B3 B2 B1	Blue LED
Byte 3	0 0 0 0 – E4 E3 E2 E1	E1: ring LEDs around encoder 1 E2: ring LEDs around encoder 2 E3: ring LEDs around encoder 3 E4: ring LEDs around encoder 4
Byte 4,7	00h	Not used

Examples:

Direction	Identifier	Format	Message	LED
To Keypad	315	Std	00 00 00 00 00 00 00 00	Turn OFF all the Key-LED
To Keypad	315	Std	80 00 00 00 00 00 00 00	Red Key-LED #8 blinks
To Keypad	315	Std	0C 00 00 00 00 00 00 00	Red Key-LED #3 and #4 blink
To Keypad	315	Std	00 40 00 00 00 00 00 00	Green Key-LED #7 blinks
To Keypad	315	Std	00 08 00 00 00 00 00 00	Green Key-LED #4 blinks
To Keypad	315	Std	00 00 30 00 00 00 00 00	Blue Key-LED #5 and #6 blink
To Keypad	315	Std	00 00 80 00 00 00 00 00	Blue Key-LED #8 blinks
To Keypad	215 315	Std Std	FF 00 00 00 00 00 00 00 FF 00 FF 00 00 00 00 00	All LED blink red and blue in alternate mode
To Keypad	315	Std	00 00 00 08 00 00 00 00	Ring LEDs around encoder 4 blink

18. Set Central and Encoder LED ON message

This command allows to switch on/off the central and the encoders' LED indicators. See the table below for the details.

Note: it is possible to adjust the brightness level of the Central and Encoder LED indicators by the [object 2003h sub-index 05h](#).

The keypad must be activated, see NMT Start CANopen Node message.

Note: in case the RPDO message is transmitted periodically to the keypad, to ensure correct processing of the command the period used must be higher than 50ms; a value equal to 100ms is fairly good for most applications.

Identifier	400h + current CAN ID	Default 415h
Byte 0	L8 L7 L6 L5 – L4 L3 L2 L1	LED encoder 1
Byte 1	L16 L15 L14 L13 – L12 L11 L10 L9	LED encoder 2
Byte 2	L24 L23 L22 L21 – L20 L19 L18 L17	LED encoder 3
Byte 3	L32 L31 L30 L29 – L28 L27 L26 L25	LED encoder 4
Byte 4	L40 L39 L38 L37 – L36 L35 L34 L33	Central LED
Byte 5	0 0 0 0 – L44 L43 L42 L41	
Byte 6,7	00h	Not used

Examples:

Direction	Identifier	Format	Message	LED
To Keypad	415	Std	01 80 00 00 00 00 00 00	LEDs 1 and 16 ON
To Keypad	415	Std	00 00 01 80 00 00 00 00	LEDs 17 and 32 ON
To Keypad	415	Std	00 00 00 00 60 00 00 00	LEDs 38 and 39 ON
To Keypad	415	Std	00 00 00 00 00 03 00 00	LEDs 41 and 42 ON

19. Backlight message

The keypad must be activated, see NMT Start CANopen Node message.

This message allows to switch on/off the backlight LEDs around the keys, the encoders and the logo (if applicable).

Note: the setting is kept at the startup.

Note 2: for the color and brightness level settings of each group of LEDs please refer to the [object 2003h](#).

Note 3: in case the RPDO message is transmitted periodically to the keypad, to ensure correct processing of the command the period used must be higher than 50ms; a value equal to 100ms is fairly good for most applications.

Identifier	500h + current CAN ID	Default 515h
Byte 0	XXh	Backlight state: 00h: OFF 01h: ON
Byte 1,7	00h	Not used

Examples:

Direction	Identifier	Format	Message	LED
To Keypad	515	Std	00 00 00 00 00 00 00 00	Switch the backlight off
To Keypad	515	Std	01 00 00 00 00 00 00 00	Switch the backlight on

SDO Messages:

A SDO (Service Data Object) is providing direct access to object entries of a CANopen device's object dictionary.

20. Object 2000h: Digital input module, keys states

This module contains all the Switch State information.

A one indicates the switch is pressed, a zero indicates the switch is released.

a) Sub 1 - Key state

This module contains all the key state information. A one indicates the key is pressed; a zero indicates the key is not pressed.

Identifier	600h + current CAN ID	Default 615h
Byte 0	40h	Read Device Register
Byte 1	00h	CAN Object 2000h
Byte 2	20h	
Byte 3	01h	Sub index
Byte 4,7	00h	Not used

Examples:

Direction	Identifier	Format	Message	Data
To Keypad	615	Std	40 00 20 01 00 00 00 00	Read keys state
From Keypad	595	Std	4B 00 20 01 00 00 00 00	No Key pressed
			4B 00 20 01 01 00 00 00	Key 1 pressed
			4B 00 20 01 02 00 00 00	Key 2 pressed
			4B 00 20 01 04 00 00 00	Key 3 pressed
			4B 00 20 01 08 00 00 00	Key 4 pressed
			4B 00 20 01 10 00 00 00	Key 5 pressed
			4B 00 20 01 20 00 00 00	Key 6 pressed
			4B 00 20 01 40 00 00 00	Key 7 pressed
			4B 00 20 01 80 00 00 00	Key 8 pressed
			4B 00 20 01 00 01 00 00	Key 9 pressed
			4B 00 20 01 00 02 00 00	Key 10 pressed
			4B 00 20 01 00 04 00 00	Key 11 pressed
			4B 00 20 01 00 08 00 00	Key 12 pressed
			4B 00 20 01 03 00 00 00	Key 1 and 2 pressed
			4B 00 20 01 00 0A 00 00	Key 10 and 12 pressed
4B 00 20 01 FF 0F 00 00	All Keys pressed			

b) Sub 2 – Read encoder 1 direction counter

This module contains the Encoder 1 direction counter.

Note: The Encoder 1 is identified with the key number 9. See [chapter 2](#) for further details.

Identifier	615h (600h + current CAN ID)	
Byte 0	40h	Read Device Register
Byte 1	00h	CAN Object 2000h
Byte 2	20h	
Byte 3	02h	Sub index
Byte 4,7	00h	Not used

From Keypad:

Identifier	595h (580h + current CAN ID)	
Byte 0	4Fh	
Byte 1	00h	CAN Object 2000h
Byte 2	20h	
Byte 3	02h	Sub index
Byte 4	XXh	Bit 7: encoder 1 direction <ul style="list-style-type: none"> • 0: Clockwise • 1: Counterclockwise Bit 0...6: Number of ticks
Byte 5,7	00h	Not used

The number of ticks is counted from the last encoder state message sent.

The counter is reset after the message is sent out.

Examples:

Direction	Identifier	Format	Message	Data
To Keypad	615	Std	40 00 20 02 00 00 00 00	
From Keypad	595	Std	4F 00 20 02 00 00 00 00	No ticks completed
			4F 00 20 02 01 00 00 00	One tick clockwise
			4F 00 20 02 81 00 00 00	One tick counterclockwise

c) Sub 3 – Read encoder 1 tick counter

The Tick counter is a two bytes counter incremented each clockwise tick and decremented each counterclockwise tick. The following command allows to read the encoder 1 tick counter value. Note: The Encoder 1 is identified with the key number 9. See [chapter 2](#) for further details.

Identifier	615h (600h + current CAN ID)	
Byte 0	40h	Read Device Register
Byte 1	00h	CAN Object 2000h
Byte 2	20h	
Byte 3	03h	Sub index
Byte 4,7	00h	Not used

From Keypad:

Identifier	595h (580h + current CAN ID)	
Byte 0	4Bh	
Byte 1	00h	CAN Object 2000h
Byte 2	20h	
Byte 3	03h	Sub index
Byte 4	XXh	Tick counter encoder 1
Byte 5	YYh	
Byte 6,7	00h	Not used

d) Sub 4 – Set/read TOP position encoder 1

The following command allows to set and read the TOP position value for the tick counter of encoder 1 (key 9).

Note: if the value 00h is selected the maximum tick counter value achievable is 65535.

Identifier	615h (600h + current CAN ID)	
Byte 0	2Fh	Set Device Register
	40h	Read Device Register
Byte 1	00h	CAN Object 2000h
Byte 2	20h	
Byte 3	04h	Sub index
Byte 4	XXh	XXh: 00h: Disabled From 02h (02) to 10h (16)
Byte 5,7	00h	Not used

Examples:

Direction	Identifier	Format	Message	Data
To Keypad	615	Std	2F 00 20 04 08 00 00 00	Set TOP position to 8
From Keypad	595	Std	60 00 20 04 00 00 00 00	Command accepted
To Keypad	615	Std	40 00 20 04 00 00 00 00	Read the set value
From Keypad	595	Std	4F 00 20 04 08 00 00 00	TOP position set to 8

e) Sub 5 – Read encoder 2 direction counter

This module contains the Encoder 2 direction counter.

Note: The Encoder 2 is identified with the key number 10. See [chapter 2](#) for further details.

Identifier	615h (600h + current CAN ID)	
Byte 0	40h	Read Device Register
Byte 1	00h	CAN Object 2000h
Byte 2	20h	
Byte 3	05h	Sub index
Byte 4,7	00h	Not used

From Keypad:

Identifier	595h (580h + current CAN ID)	
Byte 0	4Fh	
Byte 1	00h	CAN Object 2000h
Byte 2	20h	
Byte 3	05h	Sub index
Byte 4	XXh	Bit 7: encoder 1 direction <ul style="list-style-type: none"> • 0: Clockwise • 1: Counterclockwise Bit 0...6: Number of ticks
Byte 5,7	00h	Not used

The number of ticks is counted from the last encoder state message sent.

The counter is reset after the message is sent out.

Examples:

Direction	Identifier	Format	Message	Data
To Keypad	615	Std	40 00 20 05 00 00 00 00	
From Keypad	595	Std	4F 00 20 05 00 00 00 00	No ticks completed
			4F 00 20 05 01 00 00 00	One tick clockwise
			4F 00 20 05 81 00 00 00	One tick counterclockwise

f) Sub 6 – Read encoder 2 tick counter

The Tick counter is a two bytes counter incremented each clockwise tick and decremented each counterclockwise tick. The following command allows to read the encoder 2 tick counter value.

Note: The Encoder 2 is identified with the key number 10. See [chapter 2](#) for further details.

Identifier	615h (600h + current CAN ID)	
Byte 0	40h	Read Device Register
Byte 1	00h	CAN Object 2000h
Byte 2	20h	
Byte 3	06h	Sub index
Byte 4,7	00h	Not used

From Keypad:

Identifier	595h (580h + current CAN ID)	
Byte 0	4Bh	
Byte 1	00h	CAN Object 2000h
Byte 2	20h	
Byte 3	06h	Sub index
Byte 4	XXh	Tick counter encoder 2
Byte 5	YYh	
Byte 6,7	00h	Not used

g) Sub 7 – Set/read TOP position encoder 2

The following command allows to set and read the TOP position value for the tick counter of encoder 2 (key 10).

Note: if the value 00h is selected the maximum tick counter value achievable is 65535.

Identifier	615h (600h + current CAN ID)	
Byte 0	2Fh	Set Device Register
	40h	Read Device Register
Byte 1	00h	CAN Object 2000h
Byte 2	20h	
Byte 3	07h	Sub index
Byte 4	XXh	XXh: 00h: Disabled From 02h (02) to 10h (16)
Byte 5,7	00h	Not used

Examples:

Direction	Identifier	Format	Message	Data
To Keypad	615	Std	2F 00 20 04 08 00 00 00	Set TOP position to 8
From Keypad	595	Std	60 00 20 04 00 00 00 00	Command accepted
To Keypad	615	Std	40 00 20 04 00 00 00 00	Read the set value
From Keypad	595	Std	4F 00 20 04 08 00 00 00	TOP position set to 8

h) Sub 8 – Read encoder 3 direction counter

This module contains the Encoder 3 direction counter.

Note: The Encoder 3 is identified with the key number 11. See [chapter 2](#) for further details.

Identifier	615h (600h + current CAN ID)	
Byte 0	40h	Read Device Register
Byte 1	00h	CAN Object 2000h
Byte 2	20h	
Byte 3	08h	Sub index
Byte 4,7	00h	Not used

From Keypad:

Identifier	595h (580h + current CAN ID)	
Byte 0	4Fh	
Byte 1	00h	CAN Object 2000h
Byte 2	20h	
Byte 3	08h	Sub index
Byte 4	XXh	Bit 7: encoder 1 direction <ul style="list-style-type: none"> • 0: Clockwise • 1: Counterclockwise Bit 0...6: Number of ticks
Byte 5,7	00h	Not used

The number of ticks is counted from the last encoder state message sent.

The counter is reset after the message is sent out.

Examples:

Direction	Identifier	Format	Message	Data
To Keypad	615	Std	40 00 20 08 00 00 00 00	
From Keypad	595	Std	4F 00 20 08 00 00 00 00	No ticks completed
			4F 00 20 08 01 00 00 00	One tick clockwise
			4F 00 20 08 81 00 00 00	One tick counterclockwise

i) Sub 9 – Read encoder 3 tick counter

The Tick counter is a two bytes counter incremented each clockwise tick and decremented each counterclockwise tick. The following command allows to read the encoder 3 tick counter value.

Note: The Encoder 3 is identified with the key number 11. See [chapter 2](#) for further details.

Identifier	615h (600h + current CAN ID)	
Byte 0	40h	Read Device Register
Byte 1	00h	CAN Object 2000h
Byte 2	20h	
Byte 3	09h	Sub index
Byte 4,7	00h	Not used

From Keypad:

Identifier	595h (580h + current CAN ID)	
Byte 0	4Bh	
Byte 1	00h	CAN Object 2000h
Byte 2	20h	
Byte 3	09h	Sub index
Byte 4	XXh	Tick counter encoder 3
Byte 5	YYh	
Byte 6,7	00h	Not used

j) Sub 10 – Set/read TOP position encoder 3

The following command allows to set and read the TOP position value for the tick counter of encoder 1 (key 11).

Note: if the value 00h is selected the maximum tick counter value achievable is 65535.

Identifier	615h (600h + current CAN ID)	
Byte 0	2Fh	Set Device Register
	40h	Read Device Register
Byte 1	00h	CAN Object 2000h
Byte 2	20h	
Byte 3	0Ah	Sub index
Byte 4	XXh	XXh: 00h: Disabled From 02h (02) to 10h (16)
Byte 5,7	00h	Not used

Examples:

Direction	Identifier	Format	Message	Data
To Keypad	615	Std	2F 00 20 0A 08 00 00 00	Set TOP position to 8
From Keypad	595	Std	60 00 20 0A 00 00 00 00	Command accepted
To Keypad	615	Std	40 00 20 0A 00 00 00 00	Read the set value
From Keypad	595	Std	4F 00 20 0A 08 00 00 00	TOP position set to 8

k) Sub 11 – Read encoder 4 direction counter

This module contains the Encoder 4 direction counter.

Note: The Encoder 4 is identified with the key number 12. See [chapter 2](#) for further details.

Identifier	615h (600h + current CAN ID)	
Byte 0	40h	Read Device Register
Byte 1	00h	CAN Object 2000h
Byte 2	20h	
Byte 3	0Bh	Sub index
Byte 4,7	00h	Not used

From Keypad:

Identifier	595h (580h + current CAN ID)	
Byte 0	4Fh	
Byte 1	00h	CAN Object 2000h
Byte 2	20h	
Byte 3	0Bh	Sub index
Byte 4	XXh	Bit 7: encoder 1 direction <ul style="list-style-type: none"> • 0: Clockwise • 1: Counterclockwise Bit 0...6: Number of ticks
Byte 5,7	00h	Not used

The number of ticks is counted from the last encoder state message sent.

The counter is reset after the message is sent out.

Examples:

Direction	Identifier	Format	Message	Data
To Keypad	615	Std	40 00 20 0B 00 00 00 00	
From Keypad	595	Std	4F 00 20 0B 00 00 00 00	No ticks completed
			4F 00 20 0B 01 00 00 00	One tick clockwise
			4F 00 20 0B 81 00 00 00	One tick counterclockwise

l) Sub 12 – Read encoder 4 tick counter

The Tick counter is a two bytes counter incremented each clockwise tick and decremented each counterclockwise tick. The following command allows to read the encoder 4 tick counter value.

Note: The Encoder 4 is identified with the key number 12. See [chapter 2](#) for further details.

Identifier	615h (600h + current CAN ID)	
Byte 0	40h	Read Device Register
Byte 1	00h	CAN Object 2000h
Byte 2	20h	
Byte 3	0Ch	Sub index
Byte 4,7	00h	Not used

From Keypad:

Identifier	595h (580h + current CAN ID)	
Byte 0	4Bh	
Byte 1	00h	CAN Object 2000h
Byte 2	20h	
Byte 3	0Ch	Sub index
Byte 4	XXh	Tick counter encoder 4
Byte 5	YYh	
Byte 6,7	00h	Not used

m) Sub 13 – Set/read TOP position encoder 4

The following command allows to set and read the TOP position value for the tick counter of encoder 4 (key 12).

Note: if the value 00h is selected the maximum tick counter value achievable is 65535.

Identifier	615h (600h + current CAN ID)	
Byte 0	2Fh	Set Device Register
	40h	Read Device Register
Byte 1	00h	CAN Object 2000h
Byte 2	20h	
Byte 3	0Dh	Sub index
Byte 4	XXh	XXh: 00h: Disabled From 02h (02) to 10h (16)
Byte 5,7	00h	Not used

Examples:

Direction	Identifier	Format	Message	Data
To Keypad	615	Std	2F 00 20 0D 08 00 00 00	Set TOP position to 8
From Keypad	595	Std	60 00 20 0D 00 00 00 00	Command accepted
To Keypad	615	Std	40 00 20 0D 00 00 00 00	Read the set value
From Keypad	595	Std	4F 00 20 0D 08 00 00 00	TOP position set to 8

21. Object 2001h: Digital output module.

This module sets and reads the LED Outputs States. Each bit position represents the corresponding LED. A one indicates the LED is ON a zero indicates the LED is OFF.

a) Set Key-LED ON

Identifier	600h + current CAN ID	Default 615h
Byte 0	2Fh	Set Device Register
Byte 1	01h	CAN Object 2001h
Byte 2	20h	
Byte 3	XXh	XX: Sub index 01h: Red Key-LED 02h: Green Key-LED 03h: Blue Key-LED
Byte 4	YYh	L8 L7 L6 L5 L4 L3 L2 L1 Key-LED position
Byte 5,7	00h	Not used

Examples:

Direction	Identifier	Format	Message	Data
To Keypad	615	Std	2F 01 20 01 01 00 00 00	Set red LED #1 ON
From Keypad	595	Std	60 01 20 01 00 00 00 00	Command accepted
To Keypad	615	Std	2F 01 20 03 80 00 00 00	Set blue LED #8 ON
From Keypad	595	Std	60 01 20 03 00 00 00 00	Command accepted

b) Read Key-LED ON

The LED have the same mapping of Set Key-LED ON message

Identifier	600h + current CAN ID	Default 615h
Byte 0	40h	Read Device Register
Byte 1	01h	CAN Object 2001h
Byte 2	20h	
Byte 3	XXh	XX: Sub index 01h: Red Key-LED 02h: Green Key-LED 03h: Blue Key-LED
Byte 4,7	00h	Not used

Examples:

Direction	Identifier	Format	Message	Data
To Keypad	615	Std	40 01 20 01 00 00 00 00	Read red LED
From Keypad	595	Std	4F 01 20 01 02 00 00 00	Only red LED #2 ON
To Keypad	615	Std	40 01 20 02 00 00 00 00	Read green LED
From Keypad	595	Std	4F 01 20 02 80 00 00 00	Only green LED #8 ON

c) Set Encoder LED ON

Identifier	600h + current CAN ID	Default 615h	
Byte 0	23h	Set Device Register	
Byte 1	01h	CAN Object 2001h	
Byte 2	20h		
Byte 3	04h	Sub index: LED encoder ON	
Byte 4	XXh	L8 L7 L6 L5 L4 L3 L2 L1	LED encoder 1
Byte 5	YYh	L16 L15 L14 L13 L12 L11 L10 L9	LED encoder 2
Byte 6	RRh	L24 L23 L22 L21 L20 L19 L18 L17	LED encoder 3
Byte 7	ZZh	L32 L31 L30 L29 L28 L27 L26 L25	LED encoder 4

Examples:

Direction	Identifier	Format	Message	Data
To Keypad	615	Std	23 01 20 04 40 00 00 00	Set LED #7 ON
From Keypad	595	Std	60 01 20 04 00 00 00 00	Command accepted
To Keypad	615	Std	23 01 20 04 00 00 00 80	Set LED #32 ON
From Keypad	595	Std	60 01 20 04 00 00 00 00	Command accepted

d) Read Encoder LED ON

The LED have the same mapping of Set Encoder LED ON message

Identifier	600h + current CAN ID	Default 615h	
Byte 0	40h	Read Device Register	
Byte 1	01h	CAN Object 2001h	
Byte 2	20h		
Byte 3	04h	Sub index: LED encoder ON	
Byte 4,7	00h	Not used	

Examples:

Direction	Identifier	Format	Message	Data
To Keypad	615	Std	40 01 20 04 00 00 00 00	Read LED encoder ON
From Keypad	595	Std	43 01 20 04 08 00 00 00	Only LED #4 ON
To Keypad	615	Std	40 01 20 04 00 00 00 00	Read LED encoder ON
From Keypad	595	Std	43 01 20 04 00 01 00 00	Only LED #9 ON
To Keypad	615	Std	40 01 20 04 00 00 00 00	Read LED encoder ON
From Keypad	595	Std	43 01 20 04 00 00 04 00	Only LED #19 ON

e) Set Central LED ON

Identifier	600h + current CAN ID	Default 615h	
Byte 0	23h	Set Device Register	
Byte 1	01h	CAN Object 2001h	
Byte 2	20h		
Byte 3	05h	Sub index: central LED ON	
Byte 4	XXh	L40 L39 L38 L37 L36 L35 L34 L33	Central LED
Byte 5	YYh	0 0 0 0 L44 L43 L42 L41	
Byte 6,7	00h	Not used	

Examples:

Direction	Identifier	Format	Message	Data
To Keypad	615	Std	23 01 20 05 01 00 00 00	Set LED #33 ON
From Keypad	595	Std	60 01 20 05 00 00 00 00	Command accepted
To Keypad	615	Std	23 01 20 05 00 08 00 00	Set LED #44 ON
From Keypad	595	Std	60 01 20 05 00 00 00 00	Command accepted

f) Read Central LED ON

The LED have the same mapping of Set Central LED ON message

Identifier	600h + current CAN ID	Default 615h	
Byte 0	40h	Read Device Register	
Byte 1	01h	CAN Object 2001h	
Byte 2	20h		
Byte 3	05h	Sub index: central LED ON	
Byte 4,7	00h	Not used	

Examples:

Direction	Identifier	Format	Message	Data
To Keypad	615	Std	40 01 20 05 00 00 00 00	Read LED encoder ON
From Keypad	595	Std	43 01 20 05 08 00 00 00	Only LED #36 ON
To Keypad	615	Std	40 01 20 05 00 00 00 00	Read LED encoder ON
From Keypad	595	Std	43 01 20 05 00 01 00 00	Only LED #41 ON
To Keypad	615	Std	40 01 20 05 00 00 00 00	Read LED encoder ON
From Keypad	595	Std	43 01 20 05 02 00 00 00	Only LED #34 ON

g) Set Ring encoder LED ON

Identifier	600h + current CAN ID	Default 615h	
Byte 0	2Fh	Set Device Register	
Byte 1	01h	CAN Object 2001h	
Byte 2	20h		
Byte 3	06h	Sub index	
Byte 4	XXh	0 0 0 0 E4 E3 E2 E1	Ring LED around encoder
Byte 5,7	00h	Not used	

Examples:

Direction	Identifier	Format	Message	Data
To Keypad	615	Std	2F 01 20 06 01 00 00 00	Set ring encoder LED 1 ON
From Keypad	595	Std	60 01 20 06 00 00 00 00	Command accepted
To Keypad	615	Std	2F 01 20 06 02 00 00 00	Set ring encoder LED 2 ON
From Keypad	595	Std	60 01 20 06 00 00 00 00	Command accepted

h) Read Ring encoder LED ON

The LED have the same mapping of Set LED ON message

Identifier	600h + current CAN ID	Default 615h
Byte 0	40h	Read Device Register
Byte 1	01h	CAN Object 2001h
Byte 2	20h	
Byte 3	06h	Sub index
Byte 4,7	00h	Not used

Examples:

Direction	Identifier	Format	Message	Data
To Keypad	615	Std	40 01 20 06 00 00 00 00	Read ring LED around encoder
From Keypad	595	Std	4F 01 20 06 02 00 00 00	Ring LED around encoder 2 ON

22. Object 2002h: Digital output module.

This module sets and reads the LED Blink States.

Each bit position represents the corresponding LED. A one indicates the LED is blinking a zero indicates the LED is not blinking. If the blink message is sent when the LED is already ON, the LED blinks in alternate mode.

a) Set Key-LED blink

Identifier	600h + current CAN ID	Default 615h	
Byte 0	2Fh	Set Device Register	
Byte 1	02h	CAN Object 2002h	
Byte 2	20h		
Byte 3	XXh	XX: Sub index 01h: Red Key-LED 02h: Green Key-LED 03h: Blue Key-LED	
Byte 4	YYh	L8 L7 L6 L5 L4 L3 L2 L1	Key-LED position
Byte 6,7	00h	Not used	

Examples:

Direction	Identifier	Format	Message	Data
To Keypad	615	Std	2F 02 20 01 08 00 00 00	Set red LED #4 blink
From Keypad	595	Std	60 02 20 01 00 00 00 00	Command accepted
To Keypad	615	Std	2F 02 20 03 40 00 00 00	Set blue LED #7 blink
From Keypad	595	Std	60 02 20 03 00 00 00 00	Command accepted

b) Read Key-LED blink

Identifier	600h + current CAN ID	Default 615h	
Byte 0	40h	Read Device Register	
Byte 1	02h	CAN Object 2002h	
Byte 2	20h		
Byte 3	XXh	XX: Sub index 01h: Red Key-LED 02h: Green Key-LED 03h: Blue Key-LED	
Byte 4,7	00h	Not used	

Examples:

Direction	Identifier	Format	Message	Data
To Keypad	615	Std	40 02 20 01 00 00 00 00	Read red LED blink
From Keypad	595	Std	4F 02 20 01 FF 00 00 00	All red LED blink
To Keypad	615	Std	40 02 20 03 00 00 00 00	Read blue LED blink
From Keypad	595	Std	4F 02 20 03 80 00 00 00	Only blue LED #8 blinks

c) Set Encoder LED blink

Identifier	600h + current CAN ID	Default 615h	
Byte 0	23h	Set Device Register	
Byte 1	02h	CAN Object 2002h	
Byte 2	20h		
Byte 3	04h	Sub index: Set LED encoder blink	
Byte 4	XXh	L8 L7 L6 L5 L4 L3 L2 L1	LED encoder 1
Byte 5	YYh	L16 L15 L14 L13 L12 L11 L10 L9	LED encoder 2
Byte 6	RRh	L24 L23 L22 L21 L20 L19 L18 L17	LED encoder 3
Byte 7	ZZh	L32 L31 L30 L29 L28 L27 L26 L25	LED encoder 4

Examples:

Direction	Identifier	Format	Message	Data
To Keypad	615	Std	23 02 20 04 20 00 00 00	Set LED #6 blink
From Keypad	595	Std	60 02 20 04 00 00 00 00	Command accepted
To Keypad	615	Std	23 02 20 04 00 00 00 10	Set LED #29 ON
From Keypad	595	Std	60 02 20 04 00 00 00 00	Command accepted

d) Read Encoder LED blink

Identifier	600h + current CAN ID	Default 615h	
Byte 0	40h	Read Device Register	
Byte 1	02h	CAN Object 2002h	
Byte 2	20h		
Byte 3	04h	Sub index: Read LED encoder blink	
Byte 4,7	00h	Not used	

Examples:

Direction	Identifier	Format	Message	Data
To Keypad	615	Std	40 02 20 04 00 00 00 00	Read LED encoder blink
From Keypad	595	Std	43 02 20 04 04 00 00 00	Only LED #3 blinks
To Keypad	615	Std	40 02 20 04 00 00 00 00	Read LED encoder blink
From Keypad	595	Std	43 02 20 04 00 10 00 00	Only LED #13 blinks
To Keypad	615	Std	40 02 20 04 00 00 00 00	Read LED encoder blink
From Keypad	595	Std	43 02 20 04 00 00 00 40	Only LED #31 blinks

e) Set Central LED blink

Identifier	600h + current CAN ID	Default 615h	
Byte 0	23h	Set Device Register	
Byte 1	02h	CAN Object 2002h	
Byte 2	20h		
Byte 3	05h	Sub index: Set central LED blink	
Byte 4	XXh	L40 L39 L38 L37 L36 L35 L34 L33	Central LED
Byte 5	YYh	0 0 0 0 L44 L43 L42 L41	
Byte 6,7	00h	Not used	

Examples:

Direction	Identifier	Format	Message	Data
To Keypad	615	Std	23 02 20 05 02 00 00 00	Set LED #34 blinks
From Keypad	595	Std	60 02 20 05 00 00 00 00	Command accepted
To Keypad	615	Std	23 02 20 05 00 04 00 00	Set LED #43 blinks
From Keypad	595	Std	60 02 20 05 00 00 00 00	Command accepted

f) Read Central LED blink

Identifier	600h + current CAN ID	Default 615h
Byte 0	40h	Read Device Register
Byte 1	02h	CAN Object 2002h
Byte 2	20h	
Byte 3	05h	Sub index: Read central LED blink
Byte 4,7	00h	Not used

Examples:

Direction	Identifier	Format	Message	Data
To Keypad	615	Std	40 02 20 05 00 00 00 00	Read LED blink
From Keypad	595	Std	43 02 20 05 10 00 00 00	Only LED #37 blinks
To Keypad	615	Std	40 02 20 05 00 00 00 00	Read LED blink
From Keypad	595	Std	43 02 20 05 00 02 00 00	Only LED #42 blinks
To Keypad	615	Std	40 02 20 05 00 00 00 00	Read LED blinks
From Keypad	595	Std	43 02 20 05 04 00 00 00	Only LED #35 blinks

g) Set Ring encoder LED blink

Identifier	600h + current CAN ID	Default 615h	
Byte 0	2Fh	Set Device Register	
Byte 1	02h	CAN Object 2002h	
Byte 2	20h		
Byte 3	06h	Sub index	
Byte 4	XXh	0 0 0 0 E4 E3 E2 E1	Ring LED around encoder
Byte 6,7	00h	Not used	

Examples:

Direction	Identifier	Format	Message	Data
To Keypad	615	Std	2F 02 20 06 08 00 00 00	Set ring LED around encoder 4 blink
To Keypad	615	Std	60 02 20 06 00 00 00 00	Command accepted
To Keypad	615	Std	2F 02 20 06 04 00 00 00	Set ring LED around encoder 3 blink
From Keypad	595	Std	60 02 20 06 00 00 00 00	Command accepted

h) Read Ring encoder LED blink

Identifier	600h + current CAN ID	Default 615h
Byte 0	40h	Read Device Register
Byte 1	02h	CAN Object 2002h
Byte 2	20h	
Byte 3	06h	Sub index
Byte 4,7	00h	Not used

Examples:

Direction	Identifier	Format	Message	Data
To Keypad	615	Std	40 02 20 04 00 00 00 00	Read ring LED around encoder
From Keypad	595	Std	4F 02 20 02 01 00 00 00	Ring LED around encoder 1 blink

23. Object 2003h: Brightness Level

The following configuration messages allow to set independently the brightness level and color¹ of the LEDs used as indicators and backlight.

a) Default Key-LED indicators brightness level

Set message:

Note: the brightness settable range is 0-3Fh (63), but the actual available levels are 16.

Note 2: the setting is kept at the startup.

Identifier	615h (600h + current CAN ID)	
Byte 0	2Fh	Set Device Register
Byte 1	03h	CAN Object 2003h
Byte 2	20h	
Byte 3	01h	Sub index
Byte 4	YYh	Intensity 00h-3Fh → min-100%
Byte 5,7	00h	Not used

Read message:

Identifier	615h (600h + current CAN ID)	
Byte 0	40h	Read Device Register
Byte 1	03h	CAN Object 2003h
Byte 2	20h	
Byte 3	01h	Sub index
Byte 4,7	00h	Not used

Example:

Direction	Identifier	Format	Message	Data
To Keypad	615	Std	2F 03 20 01 0D 00 00 00	Brightness level = 25%
From Keypad	595	Std	60 03 20 01 00 00 00 00	Command accepted
To Keypad	615	Std	40 03 20 01 00 00 00 00	Read brightness level set
From Keypad	595	Std	4F 03 20 01 0D 00 00 00	Brightness level = 25%

¹ The color setting is available for the Key-LEDs backlight only.

b) Default Key-LED backlight brightness level

Set message:

Note: the brightness settable range is 0-3Fh (63), but the actual available levels are 16.

Note 2: the setting is kept at the startup.

Identifier	615h (600h + current CAN ID)	
Byte 0	2Fh	Set Device Register
Byte 1	03h	CAN Object 2003h
Byte 2	20h	
Byte 3	02h	Sub index
Byte 4	XXh	Intensity 00h-3Fh → 0-100%
Byte 5,7	00h	Not used

Read message:

Identifier	615h (600h + current CAN ID)	
Byte 0	40h	Read Device Register
Byte 1	03h	CAN Object 2003h
Byte 2	20h	
Byte 3	02h	Sub index
Byte 4,7	00h	Not used

Example:

Direction	Identifier	Format	Message	Data
To Keypad	615	Std	2F 03 20 02 20 00 00 00	Brightness level = 50%
From Keypad	595	Std	60 03 20 02 00 00 00 00	Command accepted
To Keypad	615	Std	40 03 20 02 00 00 00 00	Read brightness level set
From Keypad	595	Std	4F 03 20 02 20 00 00 00	Brightness level = 50%

c) Default Key-LED backlight color

Set message:

Note: the setting is kept at the startup.

Identifier	615h (600h + current CAN ID)		
Byte 0	2Fh	Set Device Register	
Byte 1	03h	CAN Object 2003h	
Byte 2	20h		
Byte 3	03h	Sub index	
Byte 4	XXh	Color 01h: red 02h: green 03h: blue 04h: yellow	05h: cyan 06h: violet 07h: white/light blue 08: amber/orange 09: yellow/green
Byte 5,7	00h	Not used	

Read message:

Identifier	615h (600h + current CAN ID)		
Byte 0	40h	Read Device Register	
Byte 1	03h	CAN Object 2003h	
Byte 2	20h		
Byte 3	03h	Sub index	
Byte 4,7	00h	Not used	

Example:

Direction	Identifier	Format	Message	Data
To Keypad	615	Std	2F 03 20 03 05 00 00 00	Cyan color set for the Key-LED backlight
From Keypad	595	Std	60 03 20 03 00 00 00 00	Command accepted
To Keypad	615	Std	40 03 20 03 00 00 00 00	Read color set for the Key-LED backlight
From Keypad	595	Std	4F 03 20 03 04 00 00 00	Cyan for Key-LED backlight color

d) Default Ring LED indicators brightness level

Set message:

Note: the setting is kept at the startup.

Identifier	615h (600h + current CAN ID)	
Byte 0	2Fh	Set Device Register
Byte 1	03h	CAN Object 2003h
Byte 2	20h	
Byte 3	04h	Sub index
Byte 4	XXh	Intensity 00h-FFh → min-100%
Byte 5,7	00h	Not used

Read message:

Identifier	615h (600h + current CAN ID)	
Byte 0	40h	Read Device Register
Byte 1	03h	CAN Object 2003h
Byte 2	20h	
Byte 3	04h	Sub index
Byte 4,7	00h	Not used

Example:

Direction	Identifier	Format	Message	Data
To Keypad	615	Std	2F 03 20 04 BF 00 00 00	Brightness level = 75%
From Keypad	595	Std	60 03 20 04 00 00 00 00	Command accepted
To Keypad	615	Std	40 03 20 04 00 00 00 00	Read brightness level set
From Keypad	595	Std	4F 03 20 04 BF 00 00 00	Brightness = 75%

e) Default Ring LED backlight brightness level

Set message:

Note: the setting is kept at the startup.

Identifier	615h (600h + current CAN ID)	
Byte 0	2Fh	Set Device Register
Byte 1	03h	CAN Object 2003h
Byte 2	20h	
Byte 3	05h	Sub index
Byte 4	XXh	Intensity 00h-FFh → 0-100%
Byte 5,7	00h	Not used

Read message:

Identifier	615h (600h + current CAN ID)	
Byte 0	40h	Read Device Register
Byte 1	03h	CAN Object 2003h
Byte 2	20h	
Byte 3	05h	Sub index
Byte 5,7	00h	Not used

Example:

Direction	Identifier	Format	Message	Data
To Keypad	615	Std	2F 03 20 05 80 00 00 00	Brightness level = 50%
From Keypad	595	Std	60 03 20 05 00 00 00 00	Command accepted
To Keypad	615	Std	40 03 20 05 00 00 00 00	Read brightness level set
From Keypad	595	Std	4F 03 20 05 80 00 00 00	Brightness level = 50%

f) Default Central and encoder LED indicators brightness level

Set message:

Note: the setting is kept at the startup.

Identifier	615h (600h + current CAN ID)	
Byte 0	2Fh	Set Device Register
Byte 1	03h	CAN Object 2003h
Byte 2	20h	
Byte 3	06h	Sub index
Byte 4	XXh	Intensity 00h-FFh → min-100%
Byte 5,7	00h	Not used

Read message:

Identifier	615h (600h + current CAN ID)	
Byte 0	40h	Read Device Register
Byte 1	03h	CAN Object 2003h
Byte 2	20h	
Byte 3	06h	Sub index
Byte 5,7	00h	Not used

Example:

Direction	Identifier	Format	Message	Data
To Keypad	615	Std	2F 03 20 06 00 00 00 00	Brightness level = min
From Keypad	595	Std	60 03 20 06 00 00 00 00	Command accepted
To Keypad	615	Std	40 03 20 06 00 00 00 00	Read brightness level set
From Keypad	595	Std	4F 03 20 06 00 00 00 00	Brightness level = min

g) Default logo LED backlight brightness level

Set message:

Note: the setting has effect on the three central LEDs used to light up the logo.

Note 2: the setting is kept at the startup.

Identifier	615h (600h + current CAN ID)	
Byte 0	2Fh	Set Device Register
Byte 1	03h	CAN Object 2003h
Byte 2	20h	
Byte 3	07h	Sub index
Byte 4	XXh	Intensity 00h-FFh → 0-100%
Byte 5,7	00h	Not used

Read message:

Identifier	615h (600h + current CAN ID)	
Byte 0	40h	Read Device Register
Byte 1	03h	CAN Object 2003h
Byte 2	20h	
Byte 3	07h	Sub index
Byte 5,7	00h	Not used

Example:

Direction	Identifier	Format	Message	Data
To Keypad	615	Std	2F 03 20 07 7F 00 00 00	Brightness level = 50%
From Keypad	595	Std	60 03 20 07 00 00 00 00	Command accepted
To Keypad	615	Std	40 03 20 07 00 00 00 00	Read brightness level set
From Keypad	595	Std	4F 03 20 07 7F 00 00 00	Brightness level = 50%

24. Object 2004h: Read Digital Input 8-bit

This object reads digital input values.

Note: please refer to [chapter 1](#) for the connector pinout.

Note 2: it is possible to connect up to 4 inputs 0-5V. For application examples please refer to [Appendix 2](#).



Warning: the input voltage range is from 0V to 5V. Do not connect input signals beyond these limits. Damage to the device may occur.

Identifier	600h + current CAN ID	Default 615h
Byte 0	40h	Read Device Register
Byte 1	04h	CAN Object 2004h
Byte 2	20h	
Byte 3	00h	Highest sub-index supported
	01h	Read input from IN0 to IN3
Byte 4,7	00h	Not used

From Keypad:

Identifier	595h (580h + current CAN ID)	
Byte 0	4Fh	Response length 1-byte
Byte 1	04h	CAN Object 2004h
Byte 2	20h	

Byte 3	00h	sub-index
Byte 4	01h	Highest sub-index supported
Byte 5,7	00h	Not used

Byte 3	01h	sub-index							
Byte 4	Not used				IN3	IN2	IN1	IN0	Digital input
	-	-	-	-	08h	04h	02h	01h	
Byte 5,7	00h	Not used							

25. Object 2005h: Read Analog Input

This object reads analog input values with 8-bit resolution. 5V=FFh.

Expected value: $(V_{in} \cdot 255/5)_h$

Note: please refer to [chapter 1](#) for the connector pinout.

Note 2: it is possible to connect up to 4 inputs 0-5V. For application examples please refer to [Appendix 2](#).



Warning: the input voltage range is from 0V to 5V. Do not connect input signals beyond these limits. Damage to the device may occur.

Identifier	600h + current CAN ID	Default 615h
Byte 0	40h	Read Device Register
Byte 1	05h	CAN Object 2005h
Byte 2	20h	
Byte 3	00h	Highest sub-index supported
	01h	Input IN0
	02h	Input IN1
	03h	Input IN2
	04h	Input IN3
Byte 4	$(V_{in} \cdot 255/5)_h$	Expected value
Byte 5,7	00h	Not used

Examples:

Direction	Identifier	Format	Message	Data
To Keypad	615	Std	40 05 20 00 00 00 00 00	Read the highest sub-index supported
From Keypad	595	Std	4F 05 20 04 00 00 00 00	04h is the highest sub-index supported
To Keypad	615	Std	40 05 20 01 00 00 00 00	Read Input IN0
From Keypad	595	Std	4F 05 20 01 33 00 00 00	1V
To Keypad	615	Std	40 05 20 02 00 00 00 00	Read Input IN1
From Keypad	595	Std	4F 05 20 02 66 00 00 00	2V
To Keypad	615	Std	40 05 20 03 00 00 00 00	Read Input IN2
From Keypad	595	Std	4F 05 20 03 99 00 00 00	3V
To Keypad	615	Std	40 05 20 04 00 00 00 00	Read Input IN3
From Keypad	595	Std	4F 05 20 04 CC 00 00 00	4V
To Keypad	615	Std	40 05 20 01 00 00 00 00	Read Input IN0
From Keypad	595	Std	4F 05 20 01 FF 00 00 00	5V

26. Object 2006h: Set analog input message period

This configuration message allows to disable or change the default transmission period of the analog input message.



Warning: the input voltage range is from 0V to 5V. Do not connect input signals beyond these limits. Damage to the device may occur.

Set message:

Identifier	615h (600h + current CAN ID)	
Byte 0	2Fh	Set Device Register
Byte 1	06h	CAN Object 2006h
Byte 2	20h	
Byte 3	00h	Sub index
Byte 4	XXh	XXh: Period in ms ÷ 10 From 08h (80ms) to C8h (2sec)
Byte 5,7	00h	Not used

Read message:

Identifier	615h (600h + current CAN ID)	
Byte 0	40h	Read Device Register
Byte 1	06h	CAN Object 2006h
Byte 2	20h	
Byte 3	00h	Sub index
Byte 4,7	00h	Not used

Example:

Direction	Identifier	Format	Message	Data
To Keypad	615	Std	2F 06 20 00 64 00 00 00	Period = 1s
From Keypad	595	Std	60 06 20 00 00 00 00 00	Command accepted
To Keypad	615	Std	40 06 20 00 00 00 00 00	Read command set
From Keypad	595	Std	4F 06 20 00 08 00 00 00	Period = 80ms

26. Object 2007h: Enable/Disable backlight

The following SDO message allows to enable/disable the backlight.

Note: the setting is kept at the startup.

Set message:

Identifier	615h (600h + current CAN ID)	
Byte 0	2Fh	Set Device Register
Byte 1	07h	CAN Object 2007h
Byte 2	20h	
Byte 3	00h	Sub index
Byte 4	XXh	00h: OFF 01h: ON
Byte 5,7	00h	Not used

Read message:

Identifier	615h (600h + current CAN ID)	
Byte 0	40h	Read Device Register
Byte 1	07h	CAN Object 2007h
Byte 2	20h	
Byte 3	00h	Sub index
Byte 4,7	00h	Not used

Example:

Direction	Identifier	Format	Message	Data
To Keypad	615	Std	2F 07 20 00 01 00 00 00	Backlight switched on
From Keypad	595	Std	60 07 20 00 00 00 00 00	Command accepted
To Keypad	615	Std	40 07 20 00 00 00 00 00	Read command set
From Keypad	595	Std	4F 07 20 00 01 00 00 00	Backlight enabled

26. Object 2008h: Enable/Disable Encoder state message

The following configuration message allows to enable/disable the encoder state message transmission.

Note: the setting is kept at the startup.

Set message:

Identifier	615h (600h + current CAN ID)	
Byte 0	2Fh	Set Device Register
Byte 1	08h	CAN Object 2008h
Byte 2	20h	
Byte 3	00h	Sub index
Byte 4	XXh	00h: disable 01h: enable (default)
Byte 5,7	00h	Not used

Read message:

Identifier	615h (600h + current CAN ID)	
Byte 0	40h	Read Device Register
Byte 1	08h	CAN Object 2008h
Byte 2	20h	
Byte 3	00h	Sub index
Byte 4,7	00h	Not used

Example:

Direction	Identifier	Format	Message	Data
To Keypad	615	Std	2F 08 20 00 00 00 00 00	Disable encoder state message transmission
From Keypad	595	Std	60 08 20 00 00 00 00 00	Command accepted
To Keypad	615	Std	40 08 20 00 00 00 00 00	Read command set
From Keypad	595	Std	4F 08 20 00 00 00 00 00	Encoder state message disabled

27. Object 2010h: Baud rate setting

Set message:

Identifier	615h (600h + current CAN ID)	
Byte 0	2Fh	Set Device Register
Byte 1	10h	CAN Object 2010h
Byte 2	20h	
Byte 3	00h	Sub index
Byte 4	00h	1000k
	01h	Reserved (force to 125k)
	02h	500k
	03h	250k
	04h	125k (Default)
	05h	Reserved (force to 125k)
	06h	50k
	07h	20k
Byte 5,7	00h	Not used

Read message:

Identifier	615h (600h + current CAN ID)	
Byte 0	40h	Read Device Register
Byte 1	10h	CAN Object 2010h
Byte 2	20h	
Byte 3	00h	Sub index
Byte 4,7	00h	Not used

Example:

Direction	Identifier	Format	Message	Data
To Keypad	615	Std	2F 10 20 00 02 00 00 00	Baud rate = 500k
From Keypad	595	Std	60 10 20 00 00 00 00 00	Command accepted
To Keypad	615	Std	40 10 20 00 00 00 00 00	Read command set
From Keypad	595	Std	4F 10 20 00 02 00 00 00	Baud rate = 500k

28. Object 2011h: Set Boot-up service

Object 2011h message enables or disables the boot up message sent by the keypad at power up to the CAN network.

Set message:

Identifier	600h + current CAN ID	Default 615h
Byte 0	2Fh	Set Device Register
Byte 1	11h	CAN Object 2011h
Byte 2	20h	
Byte 3	00h	Sub index
Byte 4	XXh	00h: Not active
		01h: Active
Byte 5,7	00h	Not used

Read message:

Identifier	600h + current CAN ID	Default 615h
Byte 0	40h	Read Device Register
Byte 1	11h	CAN Object 2011h
Byte 2	20h	
Byte 3	00h	Sub index
Byte 4,7	00h	Not used

Example:

Direction	Identifier	Format	Message	Data
To Keypad	615	Std	2F 11 20 00 00 00 00 00	Boot-up service not active
From Keypad	595	Std	60 11 20 00 00 00 00 00	Command accepted
To Keypad	615	Std	40 11 20 00 00 00 00 00	Read command set
From Keypad	595	Std	4F 11 20 00 00 00 00 00	Boot-up service not active

29. Object 2012h: Set device active on startup

If keypad is active on startup don't need the Start CANopen command from host.

Set message:

Identifier	600h + current CAN ID	Default 615h
Byte 0	2Fh	Set Device Register
Byte 1	12h	CAN Object 2012h
Byte 2	20h	
Byte 3	00h	Sub index
Byte 4	XXh	00h: Not active
		01h: Active
Byte 5,7	00h	Not used

Read message:

Identifier	600h + current CAN ID	Default 615h
Byte 0	40h	Read Device Register
Byte 1	12h	CAN Object 2012h
Byte 2	20h	
Byte 3	00h	Sub index
Byte 4,7	00h	Not used

Example:

Direction	Identifier	Format	Message	Data
To Keypad	615	Std	2F 12 20 00 01 00 00 00	Device active on startup
From Keypad	595	Std	60 12 20 00 00 00 00 00	Command accepted
To Keypad	615	Std	40 12 20 00 00 00 00 00	Read command set
From Keypad	595	Std	4F 12 20 00 01 00 00 00	Device active on startup

30. Object 2013h: Set CANopen node ID

Note: make sure that when changing node ID to the keypad, no other device on the network has the same address set.

Set message:

Identifier	600h + current CAN ID	Default 615h
Byte 0	2Fh	Set Device Register
Byte 1	13h	CAN Object 2013h
Byte 2	20h	
Byte 3	00h	Sub index
Byte 4	XXh	XX: New node id (01h-7Fh), default 15h
Byte 5,7	00h	Not used

Read message:

Identifier	600h + current CAN ID	Default 615h
Byte 0	40h	Read Device Register
Byte 1	13h	CAN Object 2013h
Byte 2	20h	
Byte 3	00h	Sub index
Byte 4,7	00h	Not used

Example:

Direction	Identifier	Format	Message	Data
To Keypad	615	Std	2F 13 20 00 19 00 00 00	CANopen node ID set to 19h
From Keypad	599	Std	60 13 20 00 00 00 00 00	Command accepted
To Keypad	619	Std	40 13 20 00 00 00 00 00	Read CANopen node ID
From Keypad	599	Std	4F 13 20 00 19 00 00 00	CANopen node ID set to 19h

31. Object 2014h: Set startup LED show

Set message:

Identifier	600h + current CAN ID	Default 615h
Byte 0	2Fh	Set Device Register
Byte 1	14h	CAN Object 2014h
Byte 2	20h	
Byte 3	00h	
Byte 4	XXh	00h: Disable
		01h: Complete LED Show (default)
		02h: Fast Flash
Byte 5,7	00h	Not used

Read message:

Identifier	600h + current CAN ID	Default 615h
Byte 0	40h	Read Device Register
Byte 1	14h	CAN Object 2014h
Byte 2	20h	
Byte 3	00h	
Byte 4,7	00h	Not used

Example:

Direction	Identifier	Format	Message	Data
To Keypad	615	Std	2F 14 20 00 00 00 00 00	Startup LED show disabled
From Keypad	595	Std	60 14 20 00 00 00 00 00	Command accepted
To Keypad	615	Std	40 14 20 00 00 00 00 00	Read command set
From Keypad	595	Std	4F 14 20 00 00 00 00 00	Startup LED show disabled

32. Object 2100h: Set DEMO mode

This message enables the Demo mode function. Demo mode is a special feature that consists in different LED states for each button pressing. Refer to the appendix “Demo mode instructions” to try these special features. Disconnect and reconnect the keypad after the sending the message to enter this mode. To exit the Demo mode, disable Demo mode command or enable another command message.

Identifier	600h + current CAN ID	Default 615h
Byte 0	2Fh	Set Device Register
Byte 1	00h	CAN Object 2100h
Byte 2	21h	
Byte 3	00h	Sub index
Byte 4	XXh	00h: Not active
		01h: Active
Byte 5,7	00h	Not used

Example:

Direction	Identifier	Format	Message	Data
To Keypad	615	Std	2F 00 21 00 01 00 00 00	Set DEMO mode Active
From Keypad	595	Std	60 00 21 00 00 00 00 00	Command accepted

33. Object 1016h: Consumer heartbeat time

The consumer heartbeat time object shall indicate the expected heartbeat cycle times. Monitoring of the heartbeat producer shall start after the reception of the first heartbeat.

NOTE 1: the heartbeat consumer time should be greater (typically twice) than the related heartbeat time to be monitored coming from the producer.

NOTE 2: if the keypad does not receive the heartbeat message producer anymore, it turns off all the LEDs eventually ON (both indicators and backlight) and goes to pre-operational state until a new NMT start message is received, even if the producer restarts to transmit the heartbeat.

NOTE 3: if the consumer heartbeat time is set with a value lower than the producer one, the keypad will not be able to change its state from pre-operational to operational.

Identifier	600h + current CAN ID	Default 615h
Byte 0	40h	Read Device Register
	23h	Set device Register
Byte 1	16h	CAN Object 1016h
Byte 2	10h	
Byte 3	ZZh	00h: Highest sub-index supported (read-only) 01h: Sub-index (read/write)
Byte 4	YYh	YYh: Heartbeat time in milliseconds LSByte
Byte 5	XXh	XXh: Heartbeat time in milliseconds MSByte
Byte 6	NNh	Node to be monitored 01h-7Fh (01h default)
Byte 7	00h	Reserved

Heartbeat time: XYYYh (from 000Ah to FFFFh: from 10 to 65535 milliseconds)

When the period is set to 0000h, the consumer heartbeat function is disabled.

Examples:

Direction	Identifier	Format	Message	Data
To Keypad	615	Std	40 16 10 00 00 00 00 00	Read highest sub-index supported
From Keypad	595	Std	4F 16 10 00 01 00 00 00	01h is the highest sub-index supported
To Keypad	615	Std	23 16 10 01 64 00 7E 00	Set heartbeat time consumer = 100ms expected from the node 7Eh
From Keypad	595	Std	60 16 10 01 00 00 00 00	Command accepted
To Keypad	615	Std	23 16 10 01 F4 01 01 00	Set heartbeat time consumer=500ms expected from the node 01h
From Keypad	595	Std	60 16 10 01 00 00 00 00	Command accepted
To Keypad	615	Std	40 16 10 01 00 00 00 00	Read heartbeat consumer time expected from the node 01h
From Keypad	595	Std	43 16 10 01 F4 01 01 00	Heartbeat consumer time set to 500ms

34. Object 1017h: Producer heartbeat time

The producer heartbeat time shall indicate the configured cycle time of the heartbeat.

Identifier	600h + current CAN ID	Default 615h
Byte 0	40h	Read Device Register
	2Bh	Set device Register
Byte 1	17h	CAN Object 1017h
Byte 2	10h	
Byte 3	00h	Sub index
Byte 4	YYh	YYh: Heartbeat time in milliseconds LSByte
Byte 5	XXh	XXh: Heartbeat time in milliseconds MSByte
Byte 6,7	00h	Not used

Heartbeat time: XYYh (from 000Ah to FEFh: from 10 to 65279 milliseconds).

When the period is set to 0000h, the producer heartbeat function is disabled.

Examples:

Direction	Identifier	Format	Message	Data
To Keypad	615	Std	40 17 10 00 00 00 00 00	Read heartbeat time
From Keypad	595	Std	4B 17 10 00 64 00 00 00	Heartbeat time = 100ms
To Keypad	615	Std	2B 17 10 00 00 00 00 00	Switch off the heartbeat
From Keypad	595	Std	60 17 10 00 00 00 00 00	Command accepted
To Keypad	615	Std	2B 17 10 00 32 00 00 00	Set heartbeat time = 50ms
From Keypad	595	Std	60 17 10 00 00 00 00 00	Command accepted
To Keypad	615	Std	2B 17 10 00 F4 01 00 00	Set heartbeat time = 500ms
From Keypad	595	Std	60 17 10 00 00 00 00 00	Command accepted

Heartbeat message

The heartbeat mechanism for a CANopen device is established by transmitting cyclically the heartbeat message by the heartbeat producer. One or more CANopen devices in the network are aware of this heartbeat message. If the heartbeat cycle fails for the heartbeat producer, the local application on the heartbeat consumer will be informed about that event.

If a CANopen device starts with a value for the heartbeat producer time unequal to 0 the boot-up message is regarded as first heartbeat message.

Identifier	700h + current CAN ID	Default 715h
Byte 0	XXh	XXh: State of heartbeat producer 00h: Boot-up 04h: Stop 05h: Operational 7Fh: Pre-operational

Example:

Direction	Identifier	Format	Message	Data
From Keypad	715h	Std	00h	Boot up
From Keypad	715h	Std	7Fh	Pre-operational
To Keypad	00h	Std	01h 15h	Start keypad with CAN ID 15h
From Keypad	715h	Std	05h	Operational

35. Object 1000h: Device Type

Identifier	600h + current CAN ID	Default 615h
Byte 0	40h	Read Device Register
Byte 1	00h	CAN Object 1000h
Byte 2	10h	
Byte 3, 7	00h	Not used

Example:

Direction	Identifier	Format	Data
To Keypad	615	Std	40 00 10 00 00 00 00 00
From Keypad	595	Std	43 00 10 00 91 01 0B 00

Device profile number 0xB0191h.

36. Object 1001h: Error Register

This object is not yet implemented in the device.

37. Object 1008h: Manufacturer Device Name

Identifier	600h + current CAN ID	Default 615h
Byte 0	40h	Read Device Register
Byte 1	08h	CAN Object 1008h
Byte 2	10h	
Byte 3, 7	00h	Not used

1° additional byte

Identifier	600h + current CAN ID	Default 615h
Byte 0	60h	Read Device Register Next Byte
Byte 1, 7	00h	Not used

2° additional byte

Identifier	600h + current CAN ID	Default 615h
Byte 0	70h	Read Device Register Next Byte
Byte 1, 7	00h	Not used

Example:

Direction	Identifier	Format	Message	Data
To Keypad	615	Std	40 08 10 00 00 00 00 00	
From Keypad	595	Std	41 08 10 00 0B 00 00 00	
To Keypad	615	Std	60 00 00 00 00 00 00 00	
From Keypad	595	Std	00 42 6C 69 6E 6B 4D 61	BlinkMa
To Keypad	615	Std	70 00 00 00 00 00 00 00	
From Keypad	595	Std	17 72 69 6E 65 00 00 00	rine

Manufacturer Device Name: BlinkMarine

The first byte of the last data message replied is 17h.

38. Object 1009h: Manufacturer Hardware Revision

Identifier	600h + current CAN ID	Default 615h
Byte 0	40h	Read Device Register
Byte 1	09h	CAN Object 1009h
Byte 2	10h	
Byte 3, 7	00h	Not used

Example:

Direction	Identifier	Format	Message	Data
To Keypad	615	Std	40 09 10 00 00 00 00 00	
From Keypad	595	Std	43 09 10 00 56 5F 30 30	V_00

Manufacturer Hardware Revision: V_00

39. Object 100Ah: Manufacturer Firmware Revision

Identifier	600h + current CAN ID	Default 615h
Byte 0	40h	Read Device Register
Byte 1	0Ah	CAN Object 100Ah
Byte 2	10h	
Byte 3, 7	00h	Not used

Example:

Direction	Identifier	Format	Message	Data
To Keypad	615	Std	40 0A 10 00 00 00 00 00	
From Keypad	595	Std	43 0A 10 00 31 2E 30 30	1.00

Manufacturer Firmware Revision: 1.00

40. Object 100Bh: Model ID

Identifier	600h + current CAN ID	Default 615h
Byte 0	40h	Read Device Register
Byte 1	0Bh	CAN Object 100Bh
Byte 2	10h	
Byte 3, 7	00h	Not used

1° additional byte

Identifier	600h + current CAN ID	Default 615h
Byte 0	60h	Read Device Register second byte
Byte 1, 7	00h	Not used

2° additional byte

Identifier	600h + current CAN ID	Default 615h
Byte 0	70h	Read Device Register third byte
Byte 1, 7	00h	Not used

Example:

Direction	Identifier	Format	Message	Data
To Keypad	615	Std	40 0B 10 00 00 00 00 00	
From Keypad	595	Std	41 0B 10 00 07 00 00 00	
To Keypad	615	Std	60 00 00 00 00 00 00 00	
From Keypad	595	Std	01 52 41 43 45 50 41 44	RACEPAD

Model ID: RACEPAD

41. Object 1011h: Restore default parameters

With this object the default values of parameters according to the communication profile, device profile, and application profile are restored. This procedure shall only be executed when the specific signature "load" is written to the sub-index 01h. When the message shown in the following table is transmitted, the default values shall be restored after the keypad is reset.

Identifier	615h (600h + current CAN ID)	
Byte 0	40h	Read Device Register
	23h	Set Device Register
Byte 1	11h	CAN Object 1011h
Byte 2	10h	
Byte 3	00h	Highest sub-index supported
	01h	Restore all parameters
Byte 4	6Ch	Character 1 "l"
Byte 5	6Fh	Character 2 "o"
Byte 6	61h	Character 3 "a"
Byte 7	64h	Character 4 "d"

Examples:

Direction	Identifier	Format	Message	Data
To Keypad	615	Std	40 11 10 00 00 00 00 00	Read highest sub-index
From Keypad	595	Std	4F 11 10 00 01 00 00 00	1
To Keypad	615	Std	23 11 10 01 6C 6F 61 64	'load'
From Keypad	595	Std	43 11 10 01 00 00 00 00	Command accepted

42. Object 1018h: Identity Data

Identifier	615h (600h + current CAN ID)	
Byte 0	40h	Read Device Register
Byte 1	18h	CAN Object 1018h
Byte 2	10h	
Byte 3	00h	Number of mapped objects
	01h	Vendor Id
	04h	Serial number
Byte 4,7	00h	Not used

Examples:

Direction	Identifier	Format	Message	Data
To Keypad	615	Std	40 18 10 00 00 00 00 00	
From Keypad	595	Std	4F 18 10 00 04 00 00 00	4
To Keypad	615	Std	40 18 10 01 00 00 00 00	
From Keypad	595	Std	43 18 10 01 E2 03 00 00	000003E2h

Blink Marine Vendor Id: 000003E2h

43. Object 1400h: Receive PDO Communication Parm 0

Describes the Receive Parameters and sets the transmission type for the Key and Ring encoder LED on state PDO Message.

Identifier	615h (600h + current CAN ID)	
Byte 0	40h	Read Device Register
	2Fh	Set Device Register
Byte 1	00h	CAN Object 1400h
Byte 2	14h	
Byte 3	00h	Number of mapped objects
	01h	COB Id
	02h	Transmission Type
Byte 4	XXh	Transmission Type (to be used only in set mode): 00h-F0h: synchronous FEh: event-driven
Byte 5,7	00h	Not used

Examples:

Direction	Identifier	Format	Message	Data
To Keypad	615	Std	40 00 14 00 00 00 00 00	
From Keypad	595	Std	4F 00 14 00 02 00 00 00	2
To Keypad	615	Std	40 00 14 01 00 00 00 00	
From Keypad	595	Std	43 00 14 01 15 02 00 00	0000 0215h
To Keypad	615	Std	40 00 14 02 00 00 00 00	
From Keypad	595	Std	4F 00 14 02 FE 00 00 00	FEh
To Keypad	615	Std	2F 00 14 02 01 00 00 00	Set Synchronous RPDO 0
From Keypad	595	Std	60 00 14 02 00 00 00 00	ACK
To Keypad	80	Std	-	SYNC message received
To Keypad	215	Std	01 00 00 00 00 00 00 00	Request LED 1 red ON: the data are buffered
To Keypad	80	Std	-	SYNC message received and message 215 processed

Receive PDO communication Parm 0:

- Number of mapped objects: 2;
- COB id: 0000 0200h + NODE ID;
- Transmission Type: synchronous or event-driven.

44. Object 1401h: Receive PDO communication Parm 1

Describes the Receive Parameters and sets the transmission type for the Key and Ring encoder LED blink PDO Message.

Identifier	615h (600h + current CAN ID)	
Byte 0	40h	Read Device Register
	2Fh	Set Device Register
Byte 1	01h	CAN Object 1401h
Byte 2	14h	
Byte 3	00h	Number of mapped objects
	01h	COB Id
	02h	Transmission Type
Byte 4	XXh	Transmission Type (to be used only in set mode): 00h-F0h: synchronous FEh: event-driven
Byte 5,7	00h	Not used

Examples:

Direction	Identifier	Format	Message	Data
To Keypad	615	Std	40 01 14 00 00 00 00 00	
From Keypad	595	Std	4F 01 14 00 02 00 00 00	2
To Keypad	615	Std	40 01 14 01 00 00 00 00	
From Keypad	595	Std	43 01 14 01 15 03 00 00	0000 0315h
To Keypad	615	Std	40 01 14 02 00 00 00 00	
From Keypad	595	Std	4F 01 14 02 FE 00 00 00	FEh
To Keypad	615	Std	2F 01 14 02 00 00 00 00	Set Synchronous RPDO 1
From Keypad	595	Std	60 01 14 02 00 00 00 00	ACK
To Keypad	80	Std	-	SYNC message received
To Keypad	315	Std	00 01 00 00 00 00 00 00	Request LED 1 green blinking: the data are buffered
To Keypad	80	Std	-	SYNC message received and message 315 processed

Receive PDO communication Parm 1:

- Number of mapped objects: 2;
- COB id: 0000 0300h + NODE ID;
- Transmission Type: synchronous or event-driven.

45. Object 1402h: Receive PDO communication Parm 2

Describes the Receive Parameters for Central and Encoder LED ON PDO Message.

Identifier	615h (600h + current CAN ID)	
Byte 0	40h	Read Device Register
	2Fh	Set Device Register
Byte 1	02h	CAN Object 1402h
Byte 2	14h	
Byte 3	00h	Number of mapped objects
	01h	COB Id
	02h	Transmission Type
Byte 4	XXh	Transmission Type (to be used only in set mode): 00h-F0h: synchronous FEh: event-driven
Byte 5,7	00h	Not used

Examples:

Direction	Identifier	Format	Message	Data
To Keypad	615	Std	40 02 14 00 00 00 00 00	
From Keypad	595	Std	4F 02 14 00 02 00 00 00	2
To Keypad	615	Std	40 02 14 01 00 00 00 00	
From Keypad	595	Std	43 02 14 01 15 04 00 00	0000 415h
To Keypad	615	Std	40 02 14 02 00 00 00 00	
From Keypad	595	Std	4F 02 14 02 FE 00 00 00	FEh
To Keypad	615	Std	2F 02 14 02 09 00 00 00	Set Synchronous RPDO 2
From Keypad	595	Std	60 02 14 02 00 00 00 00	ACK
To Keypad	80	Std	-	SYNC message received
To Keypad	415	Std	01 00 00 00 00 00 00 00	Request LED 1 ON: the data are buffered
To Keypad	80	Std	-	SYNC message received and message 415 processed

Receive PDO communication Parm 2:

- Number of mapped objects: 2;
- COB id: 0000 0400h + NODE ID;
- Transmission Type: synchronous or event-driven.

46. Object 1403h: Receive PDO communication Parm 3

Describes the Receive Parameters for backlight PDO message.

Identifier	615h (600h + current CAN ID)	
Byte 0	40h	Read Device Register
Byte 1	03h	CAN Object 1403h
Byte 2	14h	
Byte 3	00h	Highest sub-index supported
	01h	COB Id
	02h	Transmission Type
Byte 4,7	00h	Not used

Examples:

Direction	Identifier	Format	Message	Data
To Keypad	615	Std	40 03 14 00 00 00 00 00	
From Keypad	595	Std	4F 03 14 00 02 00 00 00	2
To Keypad	615	Std	40 03 14 01 00 00 00 00	
From Keypad	595	Std	43 03 14 01 15 05 00 00	0000 0515h
To Keypad	615	Std	40 03 14 02 00 00 00 00	
From Keypad	595	Std	4F 03 14 02 FE 00 00 00	FEh

Receive PDO communication Parm 3:

- Number of mapped objects: 2;
- COB id: 0000 0500h + NODE ID;
- Transmission Type: event-driven.

47. Object 1600h: Receive PDO mapping Parameter 0

Describes the mapping of Key and Ring encoder LED ON state PDO Message.

Identifier	615h (600h + current CAN ID)	
Byte 0	40h	Read Device Register
Byte 1	00h	CAN Object 1600h
Byte 2	16h	
Byte 3	00h	Number of mapped objects
	01h	PDO Mapping Entry 1
	02h	PDO Mapping Entry 2
	03h	PDO Mapping Entry 3
	04h	PDO Mapping Entry 4
Byte 4,7	00h	Not used

Examples:

Direction	Identifier	Format	Message	Data
To Keypad	615	Std	40 00 16 00 00 00 00 00	
From Keypad	595	Std	4F 00 16 00 04 00 00 00	4
To Keypad	615	Std	40 00 16 01 00 00 00 00	
From Keypad	595	Std	43 00 16 01 08 01 01 20	2001 01 08
To Keypad	615	Std	40 00 16 02 00 00 00 00	
From Keypad	595	Std	43 00 16 02 08 02 01 20	2001 02 08
To Keypad	615	Std	40 00 16 03 00 00 00 00	
From Keypad	595	Std	43 00 16 03 08 03 01 20	2001 03 08
To Keypad	615	Std	40 00 16 04 00 00 00 00	
From Keypad	595	Std	43 00 16 04 08 06 01 20	2001 06 08

Receive PDO mapping Parameter 0:

- Number of mapped objects: 4;
- Set red Key-LED: Object 2001h, Sub index 01h, Length 08h;
- Set green Key-LED: Object 2001h, Sub index 02h, Length 08h;
- Set blue Key-LED: Object 2001h, Sub index 03h, Length 08h;
- Set Ring encoder LED: Object 2001h, Sub index 06h, Length 08h.

48. Object 1601h: Receive PDO mapping Parameter 1

Describes the mapping of Key and Ring encoder LED blink state PDO Message.

Identifier	615h (600h + current CAN ID)	
Byte 0	40h	Read Device Register
Byte 1	01h	CAN Object 1601h
Byte 2	16h	
Byte 3	00h	Number of mapped objects
	01h	PDO Mapping Entry 1
	02h	PDO Mapping Entry 2
	03h	PDO Mapping Entry 3
	04h	PDO Mapping Entry 4
Byte 4,7	00h	Not used

Examples:

Direction	Identifier	Format	Message	Data
To Keypad	615	Std	40 01 16 00 00 00 00 00	
From Keypad	595	Std	4F 01 16 00 04 00 00 00	4
To Keypad	615	Std	40 01 16 01 00 00 00 00	
From Keypad	595	Std	43 01 16 01 08 01 02 20	2002 01 08
To Keypad	615	Std	40 01 16 02 00 00 00 00	
From Keypad	595	Std	43 01 16 02 08 02 02 20	2002 02 08
To Keypad	615	Std	40 01 16 03 00 00 00 00	
From Keypad	595	Std	43 01 16 03 08 03 02 20	2002 03 08
To Keypad	615	Std	40 01 16 04 00 00 00 00	
From Keypad	595	Std	43 01 16 04 08 06 02 20	2002 06 08

Receive PDO mapping Parameter 1:

- Number of mapped objects: 4;
- Set red Key-LED blink: Object 2002h, Sub index 01h, Length 08h;
- Set green Key-LED blink: Object 2002h, Sub index 02h, Length 08h;
- Set blue Key-LED blink: Object 2002h, Sub index 03h, Length 08h;
- Set Ring encoder LED blink: Object 2002h, Sub index 06h, Length 08h.

49. Object 1602h: Receive PDO mapping Parameter 2

Describes the mapping of Central and Encoder LED ON State PDO Message.

Identifier	615h (600h + current CAN ID)	
Byte 0	40h	Read Device Register
Byte 1	01h	CAN Object 1601h
Byte 2	16h	
Byte 3	00h	Number of mapped objects
	01h	PDO Mapping Entry 1
	02h	PDO Mapping Entry 2
Byte 4,7	00h	Not used

Examples:

Direction	Identifier	Format	Message	Data
To Keypad	615	Std	40 02 16 00 00 00 00 00	
From Keypad	595	Std	4F 02 16 00 02 00 00 00	2
To Keypad	615	Std	40 02 16 01 00 00 00 00	
From Keypad	595	Std	43 02 16 01 20 04 01 20	2001 04 20
To Keypad	615	Std	40 02 16 02 00 00 00 00	
From Keypad	595	Std	43 02 16 02 20 05 01 20	2001 05 20

Receive PDO mapping Parameter 2:

- Number of mapped objects: 2;
- Set Encoder LED blink: Object 2002h, Sub index 04h, Length 20h;
- Set Central LED blink: Object 2002h, Sub index 05h, Length 20h.

50. Object 1603h: Receive PDO mapping Parameter 3

Describes the mapping of backlight PDO Message.

Identifier	615h (600h + current CAN ID)	
Byte 0	40h	Read Device Register
Byte 1	03h	CAN Object 1603h
Byte 2	16h	
Byte 3,7	00h	Not used

Examples:

Direction	Identifier	Format	Message	Data
To Keypad	615	Std	40 03 16 00 00 00 00 00	
From Keypad	595	Std	43 03 16 00 01 00 00 00	1
To Keypad	615	Std	40 03 16 01 00 00 00 00	
From Keypad	595	Std	43 03 16 01 08 00 07 20	2007 00 08

Receive PDO mapping Parameter 3:

- Number of mapped objects: 1;
- Backlight message: Object 2007h, Sub index 00h, Length 08h.

51. Object 1800h:

a) Transmit PDO Communication Parm 0

Describes the Transmission Parameters and sets the transmission type for the Key state PDO Message.

Identifier	615h (600h + current CAN ID)	
Byte 0	40h	Read Device Register
	2Fh	Set Device Register
Byte 1	00h	CAN Object 1800h
Byte 2	18h	
Byte 3	00h	Highest sub-index supported
	01h	COB Id
	02h	Transmission Type
	05h	Event Timer (Periodic transmission time)
Byte 4	XXh	Transmission Type (to be used only in set mode): 01h: synchronous (cyclic every SYNC) 02h: synchronous (cyclic every 2 nd SYNC) 03h: synchronous (cyclic every 3 rd SYNC) 04h: synchronous (cyclic every 4 th SYNC) F0h: synchronous (cyclic every 240 th SYNC) FEh: event-driven (default)
Byte 5,7	00h	Not used

Examples:

Direction	Identifier	Format	Message	Data
To Keypad	615	Std	40 00 18 00 00 00 00 00	
From Keypad	595	Std	4F 00 18 00 05 00 00 00	5
To Keypad	615	Std	40 00 18 01 00 00 00 00	
From Keypad	595	Std	43 00 18 01 95 01 00 00	0000 0195h
To Keypad	615	Std	40 00 18 02 00 00 00 00	
From Keypad	595	Std	4F 00 18 02 FE 00 00 00	FEh: event-driven type
To Keypad	615	Std	40 00 18 05 00 00 00 00	
From Keypad	595	Std	4B 00 18 05 00 00 00 00	0000h: Periodic transmission disabled.
To Keypad	615	Std	2F 00 18 02 01 00 00 00	Set the Synchronous transmission (cyclic every SYNC).
From Keypad	595	Std	60 00 18 02 00 00 00 00	ACK
To Keypad	80	Std	-	SYNC message received
Key #1 pressed No message on the CAN bus				
From Keypad	195	Std	00 00 00 00 XX	Key status sent/ Read key status
To Keypad	80	Std	-	SYNC message received
From Keypad	195	Std	01 00 00 00 XX	Key status sent/ Read key status

Transmit PDO communication Parm 0:

- Highest sub-index supported: 5;
- Address base: 195h= 180h+ NODE ID;
- Transmission Type: synchronous or event-driven;
- Periodic Transmission timer: XXYY in milliseconds, 0 = OFF.

- **Set periodic state transmission**

Identifier	600h + current CAN ID	Default 615h
Byte 0	2Bh	Set device register
Byte 1	00h	CAN Object 1800h
Byte 2	18h	
Byte 3	05h	Sub index
Byte 4	YYh	YYh: Periodic transmission timer in milliseconds LSByte
Byte 5	XXh	XXh: Periodic transmission timer in milliseconds MSByte
Byte 6, 7	00h	Not used

Periodic Transmission timer: XYYh (from 0032h to FEFh: from 50 to 65279 milliseconds).

Examples:

Direction	Identifier	Format	Message	Data
To Keypad	615	Std	2B 00 18 05 00 00 00 00	Switch off the periodic state transmission
From Keypad	595	Std	60 00 18 05 00 00 00 00	Command accepted
To Keypad	615	Std	2B 00 18 05 32 00 00 00	Set period = 50ms
From Keypad	595	Std	60 00 18 05 00 00 00 00	Command accepted
To Keypad	615	Std	2B 00 18 05 F4 01 00 00	Set period = 500ms
From Keypad	595	Std	60 00 18 05 00 00 00 00	Command accepted

52. Object 1801h:

Transmit PDO Communication Parm 1

Describes the Transmission Parameters for the Encoders 1-2 state PDO Message.

Identifier	615h (600h + current CAN ID)	
Byte 0	40h	Read Device Register
Byte 1	01h	CAN Object 1801h
Byte 2	18h	
Byte 3	00h	Highest sub-index supported
	01h	COB Id
	02h	Transmission Type
	05h	Event Timer (Periodic transmission time)
Byte 4,7	00h	Not used

Examples:

Direction	Identifier	Format	Message	Data
To Keypad	615	Std	40 01 18 00 00 00 00 00	
From Keypad	595	Std	4F 01 18 00 05 00 00 00	5
To Keypad	615	Std	40 01 18 01 00 00 00 00	
From Keypad	595	Std	43 01 18 01 95 02 00 00	0000 0295h
To Keypad	615	Std	40 01 18 02 00 00 00 00	
From Keypad	595	Std	4F 01 18 02 FE 00 00 00	FEh: event-driven type
To Keypad	615	Std	40 01 18 05 00 00 00 00	
From Keypad	595	Std	4B 01 18 05 00 00 00 00	0000h: Periodic transmission disabled.

Transmit PDO communication Parm 0:

- Highest sub-index supported: 5;
- Address base: 295h= 280h+ NODE ID;
- Transmission Type: event-driven or periodic.

53. Object 1802h:

Transmit PDO Communication Parm 2

Describes the Transmission Parameters for the Encoders 3-4 state PDO Message.

Identifier	615h (600h + current CAN ID)	
Byte 0	40h	Read Device Register
Byte 1	02h	CAN Object 1802h
Byte 2	18h	
Byte 3	00h	Highest sub-index supported
	01h	COB Id
	02h	Transmission Type
	05h	Event Timer (Periodic transmission time)
Byte 4,7	00h	Not used

Examples:

Direction	Identifier	Format	Message	Data
To Keypad	615	Std	40 02 18 00 00 00 00 00	
From Keypad	595	Std	4F 02 18 00 05 00 00 00	5
To Keypad	615	Std	40 02 18 01 00 00 00 00	
From Keypad	595	Std	43 02 18 01 95 03 00 00	0000 0395h
To Keypad	615	Std	40 02 18 02 00 00 00 00	
From Keypad	595	Std	4F 02 18 02 FE 00 00 00	FEh: event-driven type
To Keypad	615	Std	40 02 18 05 00 00 00 00	
From Keypad	595	Std	4B 02 18 05 00 00 00 00	0000h: Periodic transmission disabled.

Transmit PDO communication Parm 0:

- Highest sub-index supported: 5;
- Address base: 395h= 380h+ NODE ID;
- Transmission Type: event-driven or periodic.

54. Object 1803h:

Transmit PDO Communication Parm 3

Describes the Transmission Parameters for the analog input state PDO Message.

Identifier	615h (600h + current CAN ID)	
Byte 0	40h	Read Device Register
Byte 1	03h	CAN Object 1803h
Byte 2	18h	
Byte 3	00h	Highest sub-index supported
	01h	COB Id
	02h	Transmission Type
Byte 4,7	00h	Not used

Examples:

Direction	Identifier	Format	Message	Data
To Keypad	615	Std	40 03 18 00 00 00 00 00	
From Keypad	595	Std	4F 03 18 00 02 00 00 00	02
To Keypad	615	Std	40 03 18 01 00 00 00 00	
From Keypad	595	Std	43 03 18 01 95 04 00 00	0000 0495h
To Keypad	615	Std	40 03 18 02 00 00 00 00	
From Keypad	595	Std	4F 03 18 02 XX 00 00 00	Periodic transmission each XX*ms

Transmit PDO communication Parm 0:

- Highest sub-index supported: 2;
- Address base: 495h= 480h+ NODE ID;
- Transmission Type: periodic only. *NOTE: the XXh period depends on the value set by the [Service Data Object 2006h: Set analog input message period](#).

55. Object 1A00h Transmit PDO Mapping Parameter 0

Describes the mapping of Key state PDO Message.

Identifier	615h (600h + current CAN ID)	
Byte 0	40h	Read Device Register
Byte 1	00h	CAN Object 1A00h
Byte 2	1Ah	
Byte 3	00h	Number of mapped objects
	01h	PDO Mapping Entry 1
Byte 4,7	00h	Not used

Examples:

Direction	Identifier	Format	Message	Data
To Keypad	615	Std	40 00 1A 00 00 00 00 00	
From Keypad	595	Std	4F 00 1A 00 01 00 00 00	01
To Keypad	615	Std	40 00 1A 01 00 00 00 00	
From Keypad	595	Std	43 00 1A 01 10 01 00 20	2000 01 10

Transmit PDO Mapping Parameter:

- Number of mapped objects: 1;
- Key state: Object 2000h, Sub index 01h, Length 10h.

56. Object 1A01h Transmit PDO Mapping Parameter 1

Describes the mapping of Encoders 1-2 state PDO Message.

Identifier	615h (600h + current CAN ID)	
Byte 0	40h	Read Device Register
Byte 1	01h	CAN Object 1A01h
Byte 2	1Ah	
Byte 3	00h	Number of mapped objects
	01h	PDO Mapping Entry 1
	02h	PDO Mapping Entry 2
	03h	PDO Mapping Entry 3
	04h	PDO Mapping Entry 4
	05h	PDO Mapping Entry 5
	06h	PDO Mapping Entry 6
Byte 4,7	00h	Not used

Examples:

Direction	Identifier	Format	Message	Data
To Keypad	615	Std	40 01 1A 00 00 00 00 00	
From Keypad	595	Std	4F 01 1A 00 06 00 00 00	6
To Keypad	615	Std	40 01 1A 01 00 00 00 00	
From Keypad	595	Std	43 01 1A 01 08 02 00 20	2000 02 08
To Keypad	615	Std	40 01 1A 02 00 00 00 00	
From Keypad	595	Std	43 01 1A 02 10 03 00 20	2000 03 10
To Keypad	615	Std	40 01 1A 03 00 00 00 00	
From Keypad	595	Std	43 01 1A 03 08 04 00 20	2000 04 08
To Keypad	615	Std	40 01 1A 04 00 00 00 00	
From Keypad	595	Std	43 01 1A 04 08 05 00 20	2000 05 08
To Keypad	615	Std	40 01 1A 05 00 00 00 00	
From Keypad	595	Std	43 01 1A 05 10 06 00 20	2000 06 10
To Keypad	615	Std	40 01 1A 06 00 00 00 00	
From Keypad	595	Std	43 01 1A 06 08 07 00 20	2000 07 08

Transmit PDO Mapping Parameter:

- Number of mapped objects: 6;
- Encoder 1 direction counter: Object 2000h, Sub index 02h, Length 08h;
- Encoder 1 tick counter: Object 2000h, Sub index 03h, Length 10h;
- TOP position encoder 1: Object 2000h, Sub index 04h, Length 08h;
- Encoder 2 direction counter: Object 2000h, Sub index 05h, Length 08h;
- Encoder 2 tick counter: Object 2000h, Sub index 06h, Length 10h;
- TOP position encoder 2: Object 2000h, Sub index 07h, Length 08h.

57. Object 1A02h Transmit PDO Mapping Parameter 2

Describes the mapping of Encoders 3-4 state PDO Message.

Identifier	615h (600h + current CAN ID)	
Byte 0	40h	Read Device Register
Byte 1	00h	CAN Object 1A02h
Byte 2	1Ah	
Byte 3	00h	Number of mapped objects
	01h	PDO Mapping Entry 1
	02h	PDO Mapping Entry 2
	03h	PDO Mapping Entry 3
	04h	PDO Mapping Entry 4
	05h	PDO Mapping Entry 5
	06h	PDO Mapping Entry 6
Byte 4,7	00h	Not used

Examples:

Direction	Identifier	Format	Message	Data
To Keypad	615	Std	40 02 1A 00 00 00 00 00	
From Keypad	595	Std	4F 02 1A 00 06 00 00 00	6
To Keypad	615	Std	40 02 1A 01 00 00 00 00	
From Keypad	595	Std	43 02 1A 01 08 08 00 20	2000 08 08
To Keypad	615	Std	40 02 1A 02 00 00 00 00	
From Keypad	595	Std	43 02 1A 02 10 09 00 20	2000 09 10
To Keypad	615	Std	40 02 1A 03 00 00 00 00	
From Keypad	595	Std	43 02 1A 03 08 0A 00 20	2000 0A 08
To Keypad	615	Std	40 02 1A 04 00 00 00 00	
From Keypad	595	Std	43 02 1A 04 08 0B 00 20	2000 0B 08
To Keypad	615	Std	40 02 1A 05 00 00 00 00	
From Keypad	595	Std	43 02 1A 05 10 0C 00 20	2000 0C 10
To Keypad	615	Std	40 02 1A 06 00 00 00 00	
From Keypad	595	Std	43 02 1A 06 08 0D 00 20	2000 0D 08

Transmit PDO Mapping Parameter:

- Number of mapped objects: 6;
- Encoder 3 direction counter: Object 2000h, Sub index 08h, Length 08h;
- Encoder 3 tick counter: Object 2000h, Sub index 09h, Length 10h;
- TOP position encoder 3: Object 2000h, Sub index 0Ah, Length 08h;
- Encoder 4 direction counter: Object 2000h, Sub index 0Bh, Length 08h;
- Encoder 4 tick counter: Object 2000h, Sub index 0Ch, Length 10h;
- TOP position encoder 4: Object 2000h, Sub index 0Dh, Length 08h.

58. Object 2200h: Serial number string

Identifier	600h + current CAN ID	Default 615h
Byte 0	40h	Read Device Register
Byte 1	00h	CAN Object 2200h
Byte 2	22h	
Byte 3,7	00h	Not used

1° additional byte

Identifier	600h + current CAN ID	Default 615h
Byte 0	60h	Read Device Register second byte
Byte 1, 7	00h	Not used

2° additional byte

Identifier	600h + current CAN ID	Default 615h
Byte 0	70h	Read Device Register third byte
Byte 1, 7	00h	Not used

Example:

Direction	Identifier	Format	Message	Data
To Keypad	615	Std	40 00 22 00 00 00 00 00	
From Keypad	595	Std	41 00 22 00 08 00 00 00	
To Keypad	615	Std	60 00 00 00 00 00 00 00	
From Keypad	595	Std	00 46 46 46 46 46 46 46	FFFFFF
To Keypad	615	Std	70 00 00 00 00 00 00 00	
From Keypad	595	Std	1D 46 00 00 00 00 00 00	F

Serial number: ascii FFFFFFFF

The first byte of the last data message replied is 1Dh.

APPENDIX: DEMO Mode instructions

In DEMO Mode you can try the following functions by pressing keys on the Racepad.

Entering this mode (opening feature):

- the key-LED indicators are ON with red color;
- the encoder LEDs 1-9-17-25 are ON;
- the ring LED backlight (including logo LEDs if available) is ON

Each time you press the key 1 you can change the key-LED backlight color with the following sequence:

1. Red;
2. Green;
3. Blue;
4. Yellow;
5. Cyan;
6. Magenta;
7. White/light blue;
8. Amber;
9. Yellow/green;
10. OFF.

Holding down the key 2, you can increase the key-LED indicators brightness level.

Holding down the key 3, you can decrease the key-LED indicators brightness level.

Holding down the key 9 (encoder 1), you can increase the ring LED backlight brightness level.

Holding down the key 10 (encoder 2), you can decrease the ring LED backlight brightness level.

If you press the key 4, there are different steps in this sequence:

1. Complete LED show of all colors;
2. Backlight active with keys on in sequence (it is possible to change the Key-LED indicator color by pressing key 1 and the key-LED backlight by pressing key 5);
3. Alternate blinking of Key-LED indicators 1-8 with red color; 2 with amber color; 4 with green color; 6 with white color; 7 with blue color; 5 with cyan color; 3 with yellow color.
4. Return to the opening feature.

If you press the key 8 it is possible to enable/disable the blinking of the ring encoder LEDs.

By rotating the encoders clockwise, you switch the encoders' LEDs ON; counterclockwise you switch the encoders' LEDs OFF.

NOTE: for encoder 4 (identified with key 12) the rotation also enables/disables the central LEDs.

In the case you press the other keys there are no events.

APPENDIX 2: Input application examples

This chapter shows a list of possible input applications.

NOTE: the power supply and ground available on the Input Signal Connector must be used for the external connected devices.

1. Switch high side on input 3:

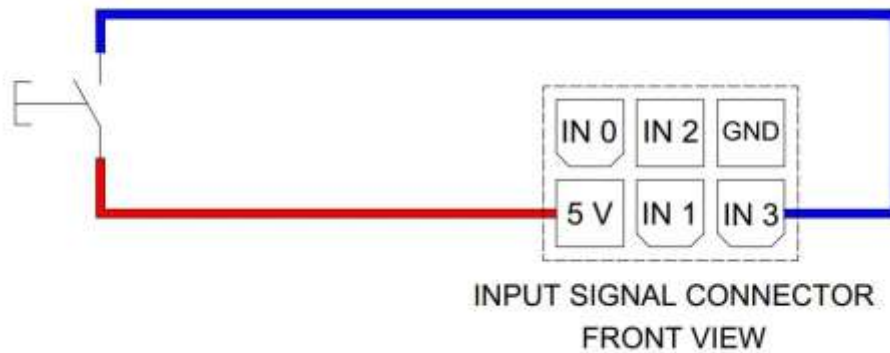

2. Switch low side on inputs 0, 1, 2, and 3:

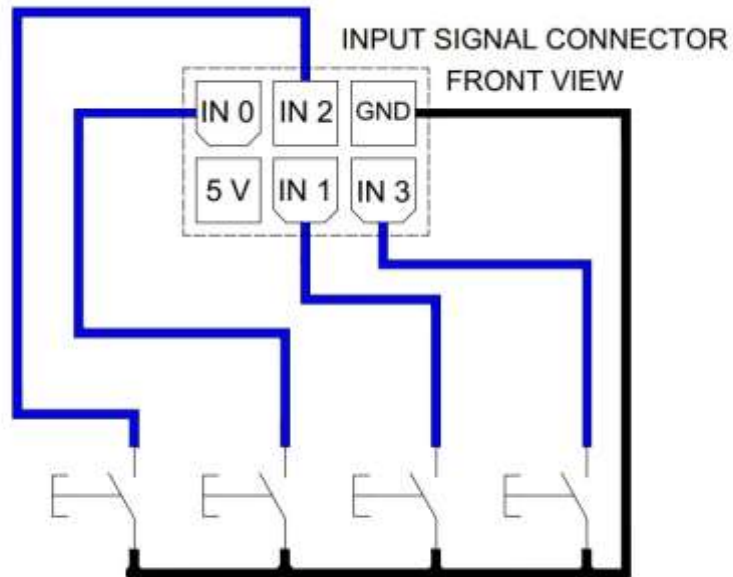

3. Digital active signal on input 2:

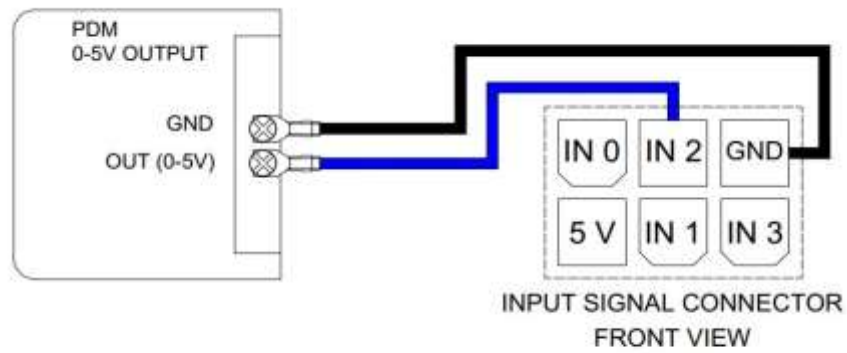

4. Active analog sensor:

- Pressure transducer – signal on input 0

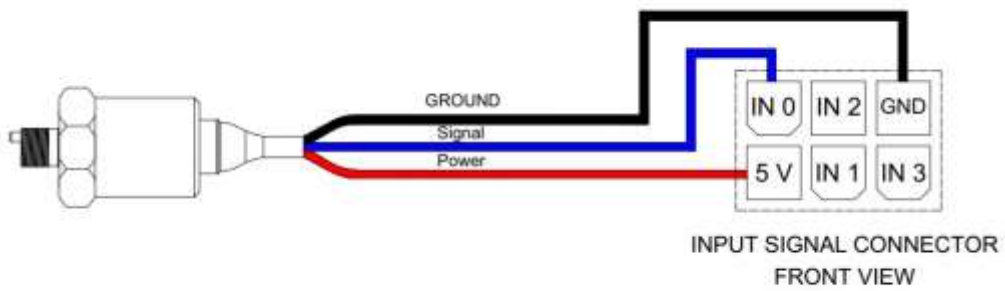

- Hall effect position sensor – signal on input 0

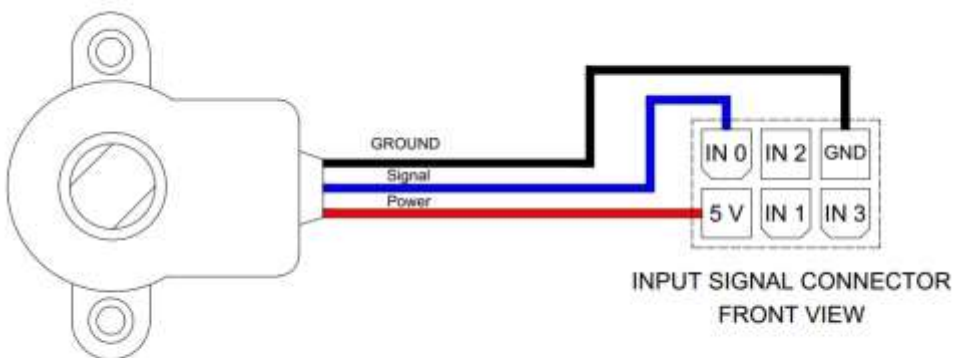

5. The use of passive sensors such as NTC thermistors, potentiometers, and all kind of variable resistors is not recommended!

59. Revision history

Date	Manual Revision	Comment
12/04/2023	1.0	First release
08/05/2023	1.1	Second release: <ul style="list-style-type: none"><li data-bbox="654 568 1209 602">• Updated descriptions in the chapters 13-14.