

Summary:

1.	How to connect the wires:	3
2.	Reference	5
3.	Message header description	6
4.	General Data Format.....	6
5.	Default Settings.....	7
6.	Key Contact state (01h).....	8
7.	Encoder 1 state message (02h)	9
8.	Encoder 2 state message (03h)	10
9.	Analog input message (04h).....	11
10.	Digital input message (0Ah)	12
11.	Key-LED command (01h).....	13
12.	Encoder LED command (0Ah)	14
13.	Set LED indicators brightness level (02h).....	15
14.	Set backlight level (03h).....	15
15.	Set startup keys message(28h)	15
16.	Get software revision (2Ah)	16
17.	Set startup LED show (34h).....	16
18.	Set startup encoder 1 tick counter value (61h)	17
19.	Set startup encoder 2 tick counter value (62h)	17
20.	Store encoder position (65h)	18
21.	Set analog input message period (6Ah)	19
22.	Set TOP position encoder 1 (6Bh)	19
23.	Set TOP position encoder 2 (6Ch)	20
24.	Set Destination Address (6Eh).....	21
25.	Baud rate setting (6Fh).....	21
26.	Set Source Address (70h)	22
27.	Periodic key-state transmission (71h).....	22
28.	Event state transmission (72h)	23
29.	LED Acknowledgment (73h).....	23
30.	Address Claim at boot (74h).....	24
31.	Heartbeat message (75h).....	25
32.	Key-state message period (77h).....	26

33. Start Demo mode(7Ah) 26

34. Default backlight brightness level (7Bh) 27

35. Default LED indicators brightness level (7Ch) 27

36. Default backlight color (7Dh) 28

37. Set CAN protocol..... 28

APPENDIX: DEMO Mode instructions..... 29

APPENDIX 2: Input application examples..... 30

38. Revision history..... 32

1. How to connect the wires:



Power Supply Connector		
Manufacturer	TE Connectivity / Deutsch	Amphenol
Connector p/n	DT04-4P	AT04-4P
Mating Connector		
Connector p/n	DT06-4S	AT06-4S
Wedgelock p/n	W4S	AW4S
Terminals p/n	0462-201-16141	AT62-201-16141



Input Signal Connector		
Manufacturer	TE Connectivity / Deutsch	Amphenol
Connector p/n	DTM04-6P	ATM04-6P
PIN	COLOUR	FUNCTION
1	Red	Power +5V
2	Yellow	IN0
3	Blue	IN1
4	Grey	IN2
5	Green	IN3
6	Black	GND
Mating Connector		
Connector p/n	DTM06-6S	ATM06-6S
Wedgelock p/n	WM6P	AWM6P
Terminals p/n	0460-202-20141 Or 1060-20-0122	AT60-202-20141 Or AT60-20-0122



Warning: the input voltage range is from 0V to 5V. Do not connect input signals beyond these limits. Damage to the device may occur.
Warning: the pin 1 (Power +5V) can source up to 1A.

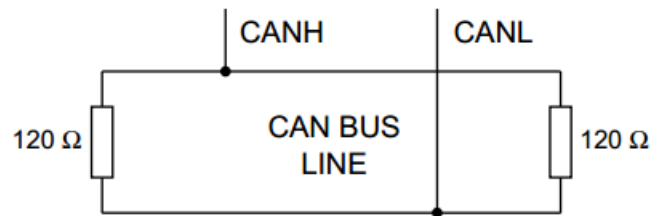

Each end of the CAN bus is terminated with 120Ω resistors in compliance with the standard to minimize signal reflections on the bus. You may need to place a 120Ω resistor between CAN-L and CAN-H.



Warning: to avoid breakage do not tighten the backshell nuts with a torque exceeding 1.8 Nm (16 lbf-in)!

2. Reference

PKP2300-MT

KEY:

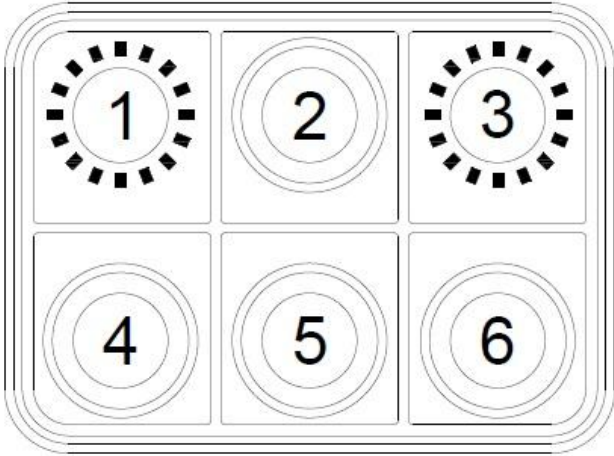

LED:

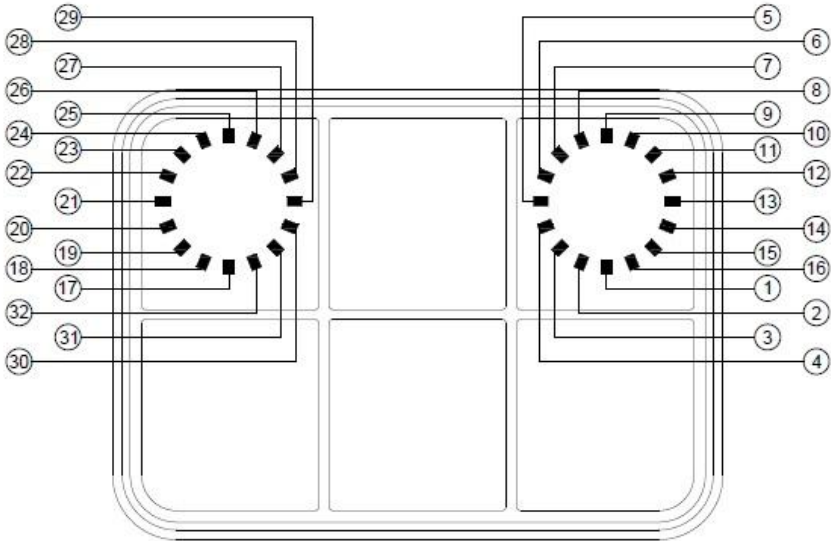

3. Message header description

The 29-bit CAN identifier used in J1939 is structured in the following way.

Priority	Reserved	Data Page	PDU Format	PDU Specific	Source Address
3 bits	1 bit	1 bit	8 bits	8 bits	8 bits

The proprietary format used by PKP keypads is defined as follows:

Priority = **6**.

Reserved = **0**.

Data page = **0**.

PDU Format = EFh (the message is addressable).

PDU Specific = Destination Address.

Parameter Group Number:

61184 (EF00h) [PROPRIETARY A] used for configuration messages and LED command;

59904 (EA00h) used for request type messages.

An example of CAN identifier of messages sent to the keypad is 18EF2100h where:

21h is the destination address (keypad)

00h is the source address.

An example of CAN identifier of messages sent by the keypad is 18EFFF21h where:

FFh refers to broadcast messages (no specific destination address)

21h is the source address (keypad).

4. General Data Format

The proprietary protocol has defined a general format for the data fields in the PGN 61184. The format consists of:

1 header field (2 bytes)

1 command byte

5 bytes (the remaining field) are defined specifically for each command.

The data length is 8 bytes, unused bits and bytes are set to all 1's (0xFF).

Byte 0	04h
Byte 1	1Bh
Byte 2	Command
Byte 3-7	Data required for each specific command

5. Default Settings

Setting	Default state or level	How to change
CAN bus baud rate	250 kbit/s	Command 6Fh
Source address	21h	Command 70h
Keypad identifier	21h	Command 70h
Destination address	FFh	Command 6Eh
Heartbeat	Disabled	Command 75h
Periodic key-state message transmission	Disabled	Command 71h
Key-state message period	100ms	Command 77h
Event state transmission	Enabled	Command 72h
Address claim at boot	Disabled	Command 74h
Default LED indicators brightness level	3Fh	Command 7Ch
Default backlight brightness level	OFF	Command 7Bh
Startup LED show	Complete LED Sequence	Command 34h
Default backlight color	Amber	Command 7Dh
LED acknowledgment	Disabled	Command 73h
Analog input message period	80ms	Command 6Ah
Startup encoder 1 tick counter value	0000h	Command 61h
Startup encoder 2 tick counter value	0000h	Command 62h
TOP position encoder 1	08h	Command 6Bh
TOP position encoder 2		Command 6Ch
Store encoder 1 position	Not active	Command 65h
Store encoder 2 position		

6. Key Contact state (01h)

This message is sent by the keypad to indicate the state of the contacts. The destination address is set to FFh: broadcast message. See chapter 2 for Key number reference.

Byte 0	04h	Header bytes
Byte 1	1Bh	
Byte 2	01h	Key Contact state
Byte 3	XXh	XX: Key number
Byte 4	YYh	Contact State 00: Key released 01: Key pressed
Byte 5	ZZh	Keypad Identifier (default 21h)
Byte 6,7	FFh	Not used

Examples:

Direction	Identifier	Format	Message	Data
From Keypad	18EFFF21h	Ext	04 1B 01 01 01 21 FF FF	Key 1 pressed
From Keypad	18EFFF21h	Ext	04 1B 01 01 00 21 FF FF	Key 1 released
From Keypad	18EFFF21h	Ext	04 1B 01 02 01 21 FF FF	Key 2 pressed
From Keypad	18EFFF21h	Ext	04 1B 01 02 00 21 FF FF	Key 2 released
From Keypad	18EFFF21h	Ext	04 1B 01 03 01 21 FF FF	Key 3 pressed
From Keypad	18EFFF21h	Ext	04 1B 01 03 00 21 FF FF	Key 3 released
From Keypad	18EFFF21h	Ext	04 1B 01 04 01 21 FF FF	Key 4 pressed
From Keypad	18EFFF21h	Ext	04 1B 01 04 00 21 FF FF	Key 4 released
From Keypad	18EFFF21h	Ext	04 1B 01 05 01 21 FF FF	Key 5 pressed
From Keypad	18EFFF21h	Ext	04 1B 01 05 00 21 FF FF	Key 5 released
From Keypad	18EFFF21h	Ext	04 1B 01 06 01 21 FF FF	Key 6 pressed
From Keypad	18EFFF21h	Ext	04 1B 01 06 00 21 FF FF	Key 6 released

If the Event state transmission is enabled, the Key Contact state message is sent when a key is switched.

If the periodic key-state transmission is enabled (see [Command 71h](#) for further details), at each given time interval a Key Contact state message is transmitted for each button of the keypad.

7. Encoder 1 state message (02h)

This message is sent by the keypad to indicate the state of the encoder 1. The destination address is set to FFh: broadcast message.

Note: the encoder 1 is identified with the key number 1. See [chapter 2](#) for further details.

The state of the encoder 1 is represented by 3 counter fields:

- The Direction counter (Byte 3) transmits the number of ticks and the direction of the encoder rotation since the last message sent. The MSB of the counter defines the direction.
- The Tick counter (Byte 4 and 5) is a two bytes counter incremented each clockwise tick and decremented each counterclockwise tick.
- The TOP position (Byte 6): when is different from 00h, it is the maximum value the encoder tick counter will count up to. In this case, with each clockwise tick the counter increases until the TOP position is reached; once reached this value, each further tick in this direction does not increase the counter. On the contrary, with each counterclockwise tick the counter decreases from the current value to zero; once reached zero, each further tick in this direction does not change the counter value.

NOTE: the default TOP position value is 08h, but can be changed by using the configuration command [Set TOP position encoder 1 \(6Bh\)](#). In case it is selected the value 00h the maximum encoder tick counter value is 65535.

NOTE: the default startup tick counter value for the encoder 1 is zero, but it is possible to change it by using [Command 61h](#).

NOTE: in case it is enabled the store of the encoder position by [Command 65h](#), it is not possible to set a startup tick counter value for the encoder 1; when the command status switches from “not active” to “active” and vice versa, the current encoder tick counter and the startup tick counter values are reset to zero.

Byte 0	04h	Header bytes
Byte 1	1Bh	
Byte 2	02h	Encoder 1 state message
Byte 3	Encoder Direction counter X Y Y Y – Y Y Y Y b	X = 0 clockwise, X = 1 counterclockwise. YYYYYYY = number of Ticks. 1 Turn (360° rotation) = 16 Ticks
Byte 4, 5	ZZ ZZh	Encoder Tick counter
Byte 6	00h or RRh	TOP position encoder 1
Byte 7	ZZh	Keypad Identifier (default 21h)

Examples:

Direction	Identifier	Format	Message	Data
From Keypad	18EFFF21h	Ext	04 1B 02 01 00 01 08 21	1 Tick CW with 08h as TOP position
From Keypad	18EFFF21h	Ext	04 1B 02 81 FF FF 00 21	1 Tick CCW

8. Encoder 2 state message (03h)

This message is sent by the keypad to indicate the state of the encoder 2. The destination address is set to FFh: broadcast message.

Note: the encoder 2 is identified with the key number 3. See [chapter 2](#) for further details.

The state of the encoder 1 is represented by 3 counter fields:

- The Direction counter (Byte 3) transmits the number of ticks and the direction of the encoder rotation since the last message sent. The MSB of the counter defines the direction.
- The Tick counter (Byte 4 and 5) is a two bytes counter incremented each clockwise tick and decremented each counterclockwise tick.
- The TOP position (Byte 6): when is different from 00h, it is the maximum value the encoder tick counter will count up to. In this case, with each clockwise tick the counter increases until the TOP position is reached; once reached this value, each further tick in this direction does not increase the counter. On the contrary, with each counterclockwise tick the counter decreases from the current value to zero; once reached zero, each further tick in this direction does not change the counter value.

NOTE: the default TOP position value is 08h, but can be changed by using the configuration command [Set TOP position encoder 2\(6Ch\)](#). In case it is selected the value 00h the maximum encoder tick counter value is 65535.

NOTE: the default startup tick counter value for the encoder 2 is zero, but it is possible to change it by using [Command 62h](#).

NOTE: in case it is enabled the store of the encoder position by [Command 65h](#), it is not possible to set a startup tick counter value for the encoder 2; when the command status switches from “not active” to “active” and vice versa, the current encoder tick counter and the startup tick counter values are reset to zero.

Byte 0	04h	Header bytes
Byte 1	1Bh	
Byte 2	03h	Encoder 2 state message
Byte 3	Encoder Direction counter X Y Y Y – Y Y Y Y b	X = 0 clockwise, X = 1 counterclockwise. YYYYYYY = number of Ticks. 1 Turn (360° rotation) = 16 Ticks
Byte 4, 5	ZZ ZZh	Encoder Tick counter
Byte 6	00h or RRh	TOP position encoder 2
Byte 7	ZZh	Keypad Identifier (default 21h)

Examples:

Direction	Identifier	Format	Message	Data
From Keypad	18EFFF21h	Ext	04 1B 03 01 00 01 10 21	1 Tick CW with 10h as TOP position
From Keypad	18EFFF21h	Ext	04 1B 03 81 FF FF 00 21	1 Tick CCW

9. Analog input message (04h)

This message transmits periodically the analog values with 8-bit resolution of each of the four inputs.

The default transmission period is 80ms, but it is possible to change by the configuration command [Set analog input message period \(6Ah\)](#).

Note: please refer to [chapter 1](#) for the connector pinout.

Note 2: it is possible to connect up to 4 inputs 0-5V. For application examples refer to appendix 2.



Warning: the input voltage range is from 0V to 5V. Do not connect input signals beyond these limits. Damage to the device may occur.

Byte 0	04h	Header bytes
Byte 1	1Bh	
Byte 2	04h	Analog input message
Byte 3	$(V_{in} \cdot 255/5)h$	Input 0
Byte 4		Input 1
Byte 5		Input 2
Byte 6		Input 3
Byte 7	XXh	Keypad Identifier (default 21h)

Examples:

Direction	Identifier	Format	Message	Data
From Keypad	18EFFF21h	Ext	04 1B 04 33 66 00 00 21	INPUT 0 = 1V INPUT 1 = 2V INPUT 2 = 0V INPUT 3 = 0V
From Keypad	18EFFF21h	Ext	04 1B 04 00 99 CC FF 21	INPUT 0 = 0V INPUT 1 = 3V INPUT 2 = 4V INPUT 3 = 5V

10. Digital input message (0Ah)

By this command message, it is possible to read the digital input value.

Note: please refer to [chapter 1](#) for the connector pinout.

Note 2: it is possible to connect up to 4 inputs 0-5V. For application examples please refer to [Appendix 2](#).



Warning: the input voltage range is from 0V to 5V. Do not connect input signals beyond these limits. Damage to the device may occur.

Identifier	18EA2100h	
Byte 0	0Ah	Read digital input 8-bit
Byte 1	00h	Single frame
Byte 2	01h	Enable reading

Answer:

Identifier	18EAF21h					
Byte 0	0Ah					Command byte
Byte 1	00h					Single frame
Byte 2	XXh					06h: command understood (ACK) 15h: command non accepted
Byte 3	Not used	IN3	IN2	IN1	INO	'1': digital input
	-	08h	04h	02h	01h	
Byte 4,7	00h					Not used

11. Key-LED command (01h)

The following message sent to the keypad allows to switch on/off the Key-LED indicators with the color and state shown in the table below.

See [chapter 2](#) for Key-LED number reference.

Byte 0	04h	Header bytes
Byte 1	1Bh	
Byte 2	01h	Key-LED command
Byte 3	XXh	XX: Key-LED number 2,4,5,6 (02h-04h-05h-06h)
Byte 4	00h or YYh	LED Color (only for Key-LED) 00h: off 01h: red 02h: green 03h: blue 04h: yellow 05h: cyan 06h: magenta 07h: white/light blue 08h: amber/orange 09h: yellow/green
Byte 5	ZZh	LED State 00h: off 01h: on 02h: blink 03h: alternate blink
Byte 6	WWh	LED Secondary Color (only for Key-LED and alt blink) 00h: off 01h: red 02h: green 03h: blue 04h: yellow 05h: cyan 06h: magenta 07h: white/light blue 08h: amber/orange 09h: yellow/green
Byte 7	FFh	Not used

Examples:

Direction	Identifier	Format	Message	Data
To Keypad	18EF2100h	Ext	04 1B 01 05 06 01 00 FF	Key-LED 5 magenta on
To Keypad	18EF2100h	Ext	04 1B 01 02 03 02 00 FF	Key-LED 2 blinks blue
To Keypad	18EF2100h	Ext	04 1B 01 04 01 02 00 FF	Key-LED 1 blinks red
To Keypad	18EF2100h	Ext	04 1B 01 06 04 01 00 FF	Key-LED 6 yellow on
To Keypad	18EF2100h	Ext	04 1B 01 05 01 03 02 FF	Key-LED 5 blinks red and green in alternate mode

12. Encoder LED command (0Ah)

The following message sent to the keypad allows to switch on/off the encoder LED indicators with the state shown in the table below.

See [chapter 2](#) for encoder LED number reference.

Byte 0	04h	Header bytes
Byte 1	1Bh	
Byte 2	0Ah	Encoder LED command
Byte 3	XXh	XX: Encoder LED number 1-32 01h-20h
Byte 4	YYh	LED State 00h: off 01h: on 02h: blink
Byte 5,7	FFh	Not used

Examples:

Direction	Identifier	Format	Message	Data
To Keypad	18EF2100h	Ext	04 1B 0A 02 01 00 00 00	Encoder LED 2 on
To Keypad	18EF2100h	Ext	04 1B 0A 07 01 00 00 00	Encoder LED 7 on
To Keypad	18EF2100h	Ext	04 1B 0A 0C 02 00 00 00	Encoder LED 12 blinks
To Keypad	18EF2100h	Ext	04 1B 0A 14 02 00 00 00	Encoder LED 20 blinks
To Keypad	18EF2100h	Ext	04 1B 0A 0F 01 00 00 00	Encoder LED 15 on

13. Set LED indicators brightness level (02h)

This message sets the value of the LED indicators brightness level. The value can be set from 0 to 3Fh (min-100%) of the LED dimming range.

NOTE: this setting has temporary effect and at the startup comes back to the default value. If the default value is desired to change, please refer to the [Command 7Ch](#).

Byte 0	04h	Header bytes
Byte 1	1Bh	
Byte 2	02h	Set LED indicators brightness level
Byte 3	XXh	XX: Dim Value (default 3Fh) From 00h (min) to 3Fh (100%)
Byte 4,7	FFh	Not used

Example:

Direction	Identifier	Format	Message	Data
To Keypad	18EF2100h	Ext	04 1B 02 20 FF FF FF FF	Brightness level set to 50%

14. Set backlight level (03h)

This message sets the value of the backlight brightness. The value can be set from 0 to 3Fh (0-100%) of the brightness range.

NOTE: this setting has temporary effect and at the startup comes back to the default value. If the default value is desired to change, please refer to the [Command 7Bh](#).

Byte 0	04h	Header bytes
Byte 1	1Bh	
Byte 2	03h	Set backlight level
Byte 3	XXh	XX: Value (default 00h) From 00h (0%) to 3Fh (100%)
Byte 4,7	FFh	Not used

Example:

Direction	Identifier	Format	Message	Data
To Keypad	18EF2100h	Ext	04 1B 03 3F FF FF FF FF	Backlight level set to 100%

15. Set startup keys message(28h)

This command enables the transmission of the state of the keys during power up.

Byte 0	04h	Header bytes
Byte 1	1Bh	
Byte 2	28h	Set startup keys message
Byte 3	XXh	XX: 00h Disabled (default) 01h Enabled
Byte 4,7	FFh	Not used

Example:

Direction	Identifier	Format	Message	Data
To Keypad	18EF2100h	Ext	04 1B 28 01 FF FF FF FF	Startup keys message enabled

16. Get software revision (2Ah)

Byte 0	04h	Header bytes
Byte 1	1Bh	
Byte 2	2Ah	Get software revision
Byte 3,7	FFh	Not used

Answer:

Byte 0	04h	Header bytes
Byte 1	1Bh	
Byte 2	2Ah	Get software revision
Byte 3,6	XXh XXh XXh XXh	SW revision ASCII
Byte 7	00h	Not used

Example

Direction	Identifier	Format	Message	Data
To Keypad	18EF2100h	Ext	04 1B 2A FF FF FF FF FF	Get software revision
From Keypad	18EFFF21h	Ext	04 1B 2A 31 2E 30 30 00	1.00

17. Set startup LED show (34h)

Byte 0	04h	Header bytes
Byte 1	1Bh	
Byte 2	34h	Set startup LED show
Byte 3	XXh	XX: 00h OFF 01h Complete LED show (default) 02h Fast flash
Byte 4,7	FFh	Not used

Example

Direction	Identifier	Format	Message	Data
To Keypad	18EF2100h	Ext	04 1B 34 02 FF FF FF FF	Fast flash show enabled

18. Set startup encoder 1 tick counter value (61h)

The following command allows to set the desired encoder 1 tick counter value at the startup.

NOTE: in case the TOP position has been set, if it is selected a startup counter value higher than the TOP position, the counter starts from the TOP position.

NOTE: in case the Store encoder 1 position is enabled ([Command 65h](#)), the startup encoder tick value setting for encoder 1 is not available.

Byte 0	04h	Header bytes
Byte 1	1Bh	
Byte 2	61h	Startup encoder tick counter value
Byte 3	YYh	Tick counter value LSByte
Byte 4	XXh	Tick counter value MSByte
Byte 5,7	FFh	Not used

Encoder tick counter value: XYYYh (from 0000h to FFFFh: from 0 to 65535)

Examples:

Direction	Identifier	Format	Message	Data
To Keypad	18EF2100h	Ext	04 1B 61 10 00 FF FF FF	Encoder tick counter value set to 16
From Keypad	18EFFF21h	Ext	04 1B 02 01 11 00 00 21	1 Tick CW
From Keypad	18EFFF21h	Ext	04 1B 02 81 0F 00 00 21	1 Tick CCW

19. Set startup encoder 2 tick counter value (62h)

The following command allows to set the desired encoder 2 tick counter value at the startup.

NOTE: in case the TOP position has been set, if it is selected a startup counter value higher than the TOP position, the counter starts from the TOP position.

NOTE: in case the Store encoder 2 position is enabled (Command 65h), the startup encoder tick value setting for encoder 2 is not available.

Byte 0	04h	Header bytes
Byte 1	1Bh	
Byte 2	62h	Startup encoder tick counter value
Byte 3	YYh	Tick counter value LSByte
Byte 4	XXh	Tick counter value MSByte
Byte 5,7	FFh	Not used

Encoder tick counter value: XYYYh (from 0000h to FFFFh: from 0 to 65535)

Examples:

Direction	Identifier	Format	Message	Data
To Keypad	18EF2100h	Ext	04 1B 62 05 00 FF FF FF	Encoder tick counter value set to 5
From Keypad	18EFFF21h	Ext	04 1B 03 01 06 00 00 21	1 Tick CW
From Keypad	18EFFF21h	Ext	04 1B 03 81 04 00 00 21	1 Tick CCW

20. Store encoder position (65h)

This object allows to save the last position reached by the encoders in non-volatile memory. At the startup the encoder counter starts from the last position reached before the device is powered off.

Note: in case this command is enabled for a given encoder, the startup encoder tick value setting for the related encoder (see Commands 61h-62h) is not available.

Note: when the command status from “not active” to “active” and vice versa, the startup tick counter value is reset to zero.

Byte 0	04h	Header bytes
Byte 1	1Bh	
Byte 2	65h	Store encoder position
Byte 3	XXh (encoder 1)	00h: Not active
Byte 4	YYh (encoder 2)	01h: Active
Byte 5,7	FFh	Not used

Example:

Direction	Identifier	Format	Message	Data
To Keypad	18EF2100h	Ext	04 1B 65 00 01 FF FF FF	Store encoder 2 position enabled

21. Set analog input message period (6Ah)

This configuration message allows to disable the periodic transmission or change the default transmission period of the [analog input message 04h](#).

Byte 0	04h	Header bytes
Byte 1	1Bh	
Byte 2	6Ah	Set analog input message period
Byte 3	XXh	XXh: Period in ms ÷ 10 From 08h (80ms) to C8h (2sec) 00h: periodic analog input message disabled
Byte 4,7	FFh	Not used

Example:

Direction	Identifier	Format	Message	Data
To Keypad	18EF2100h	Ext	04 1B 6A 0A FF FF FF FF	Period = 100ms

22. Set TOP position encoder 1 (6Bh)

The following command allows to set the TOP position value for the tick counter of encoder 1.

Note: if the value 00h is selected the maximum tick counter value achievable is 65535.

Note 2: the encoder 1 is identified with the key number 1. See [chapter 2](#) for further details.

Byte 0	04h	Header bytes
Byte 1	1Bh	
Byte 2	6Bh	Set TOP position encoder 1
Byte 3	XXh	XXh: 00h: Disabled From 02h (02) to 10h (16)
Byte 4,7	FFh	Not used

Example:

Direction	Identifier	Format	Message	Data
To Keypad	18EF2100h	Ext	04 1B 6B 10 FF FF FF FF	TOP position set to 16

23. Set TOP position encoder 2 (6Ch)

The following command allows to set the TOP position value for the tick counter of encoder 2.

Note: if the value 00h is selected the maximum tick counter value achievable is 65535.

Note 2: the encoder 2 is identified with the key number 3. See [chapter 2](#) for further details.

Byte 0	04h	Header bytes
Byte 1	1Bh	
Byte 2	6Ch	Set TOP position encoder 2
Byte 3	XXh	XXh: 00h: Disabled From 02h (02) to 10h (16)
Byte 4,7	FFh	Not used

Example:

Direction	Identifier	Format	Message	Data
To Keypad	18EF2100h	Ext	04 1B 6C 05 FF FF FF FF	TOP position set to 5

24. Set Destination Address (6Eh)

This message is used to set the addressee node of the Key Contact state transmitted by the keypad. The default destination address is FFh (broadcast).

Byte 0	04h	Header bytes
Byte 1	1Bh	
Byte 2	6Eh	Set Destination Address
Byte 3	XXh	XX: CAN Destination Address From 00h to FFh FEh: reserved
Byte 4,7	FFh	Not used

Example:

Direction	Identifier	Format	Message	Data
To Keypad	18EF2100h	Ext	04 1B 6E 15 FF FF FF FF	CAN destination address set to 15h

25. Baud rate setting (6Fh)

This message is used to change the baud rate of the CAN bus. Connecting only one keypad to the bus when changing the baud rate is recommended. If an invalid value is chosen, then no change is done to the stored value.

Byte 0	04h	Header bytes
Byte 1	1Bh	
Byte 2	6Fh	Baud rate setting
Byte 3	02h	500kbit/s
	03h	250kbit/s
Byte 4,7	FFh	Not used

Example

Direction	Identifier	Format	Message	Data
To Keypad	18EF2100h	Ext	04 1B 6F 02 FF FF FF FF	Baud rate set to 500kbit/s

26. Set Source Address (70h)

This message is used to change the keypad CAN Source Address and/or the Keypad Identifier. Either or both the Source Address or Keypad Identifier may be changed independently. Connecting only one keypad to the bus when changing the keypad address is recommended. If an invalid value is chosen, then no change is done to the stored value.

Byte 0	04h	Header bytes
Byte 1	1Bh	
Byte 2	70h	Set Source Address
Byte 3	XXh	XX: CAN Source Address From 01h to FDh FEh: reserved FFh: no change
Byte 4	YYh	YY: Keypad Identifier From 01h to FDh FEh: reserved FFh: no change
Byte 5,7	FFh	Not used

Example:

Direction	Identifier	Format	Message	Data
To Keypad	18EF2100h	Ext	04 1B 70 33 33 FF FF FF	Source address set to 33h; keypad identifier set to 33h.

27. Periodic key-state transmission (71h)

This message enables or disables the periodic transmission of the Key state.

When enabled, one contact state message is periodically sent for each button of the keypad.

The period is set to 100ms as default value but can be changed through [command 77h](#).

Byte 0	04h	Header bytes
Byte 1	1Bh	
Byte 2	71h	Periodic state transmission message
Byte 3	XXh	XX: 00h Disabled (default) 01h Enabled
Byte 4,7	FFh	Not used

Example:

Direction	Identifier	Format	Message	Data
To Keypad	18EF2100h	Ext	04 1B 71 01 FF FF FF	Periodic key-state transmission enabled

28. Event state transmission (72h)

This message enables or disables event-driven key state transmissions. When this feature is enabled, the keypad transmits the state of a contact at the time that the contact changes state (pressed or released).

Byte 0	04h	Header bytes
Byte 1	1Bh	
Byte 2	72h	Event state transmission
Byte 3	XXh	XX: 00h Disabled 01h Enabled (default)
Byte 4,7	FFh	Not used

Example:

Direction	Identifier	Format	Message	Data
To Keypad	18EF2100h	Ext	04 1B 72 01 FF FF FF FF	Event state transmission enabled

29. LED Acknowledgment (73h)

This command enables or disables the transmission of the LED Acknowledgment message. When this feature is enabled the keypad transmits an acknowledgement message each time a LED Command is received.

Note: the message is available for the Key-LED command only.

Byte 0	04h	Header bytes
Byte 1	1Bh	
Byte 2	73h	LED Acknowledgement
Byte 3	XXh	XX: 00h Disabled (default) 01h Enabled
Byte 4,7	FFh	Not used

Example:

Direction	Identifier	Format	Message	Data
To Keypad	18EF2100h	Ext	04 1B 73 01 FF FF FF FF	LED acknowledgment enabled
To Keypad	18EF2100h	Ext	04 1B 01 01 04 03 05 FF	Key-LED Command
From Keypad	18EFFF21h	Ext	00 03 01 04 05 FF FF FF	LED Ack message

LED Acknowledgment message:

Byte 0	00h	
Byte 1	XXh	XX: Key-LED state
Byte 2	YYh	YY: Key number
Byte 3	PPh	PP: Primary color
Byte 4	ZZh	ZZ: Secondary color
Byte 5,7	FFh	Not used

30. Address Claim at boot (74h)

This message enables or disables the address claim procedure.

Byte 0	04h	Header bytes
Byte 1	1Bh	
Byte 2	74h	Address claim at boot
Byte 3	XXh	XX: 00h Disabled (default) 01h Enabled
Byte 4,7	FFh	Not used

Example:

Direction	Identifier	Format	Message	Data
To Keypad	18EF2100h	Ext	04 1B 74 01 FF FF FF FF	Address claim enabled

Address claiming procedure:

Under normal operation, the keypad application sends an Address Claim parameter group at start up and waits up to 250ms for the other devices connected to the same network to send a message containing the device's address and name. The keypad checks every response and compares the names to see who has the highest priority. If a device is already using the address and has a higher priority, then a new address is selected, and the process starts over. If the keypad has a higher priority than the device in use then it waits for other systems to reply, while the responding device will have to change its address and send an address claim itself. If no message is received after the time (250ms) is up, then the device has claimed the address.

Address claim parameter group:

Priority = 6.

Destination Address should always be the Global Address FFh

Parameter Group Number (PGN) = 60928(EE00h).

Data Length = 8

Data = NAME field

Example:

Direction	Identifier	Format	Message	Data
From Keypad	18EEFF21h	Ext	1F FF FF 03 04 00 82 3C	

31. Heartbeat message (75h)

This command enables or disables the transmission of Heartbeat message. This message, containing information on the keys/digital inputs state, is designed to indicate to other devices on the bus that this unit continues to function.

NOTE: The command can be set so that the heartbeat message transmits both the keys and the digital inputs state or only the keys state information.

Byte 0	04h	Header bytes
Byte 1	1Bh	
Byte 2	75h	Heartbeat message
Byte 3	XXh	XX: 00h: Disabled (default) 01h: Enable Heartbeat with key state information 02h: Enable Heartbeat with key and digital input state information
Byte 4	YYh	YY: Period in milliseconds ÷ 10 From 05h (50ms) to FEh (2.54 sec)
Byte 5,7	FFh	Not used

Example:

Direction	Identifier	Format	Message	Data
To Keypad	18EF2100h	Ext	04 1B 75 01 32 FF FF FF	Enable Heartbeat message with key state information each 500ms

Heartbeat generated message:

Byte 0	04h	Header bytes				
Byte 1	1Bh					
Byte 2	F9h	Heartbeat message				
Byte 3	XXh	XX: Message counter, incremented each message sent				
Byte 4	0 0 K6 K5 K4 K3 K2 K1	Key state indicators Each bit represents a key state 0: OFF 1: ON				
Byte 5	00h	Not used				
Byte 6	Not used	IN3	IN2	IN1	IN0	FFh or XXh: Digital input state (if enabled) Each bit represents an input '1': digital input
	-	08h	04h	02h	01h	
Byte 7	21h	Keypad identifier				

Example:

Direction	Identifier	Format	Message	Data
From Keypad	18EFFF21h	Ext	04 1B F9 F1 20 00 01 21	Heartbeat message with key 6 pressed and digital input 0 in HIGH state
From Keypad	18EFFF21h	Ext	04 1B F9 F2 01 00 FF 21	Heartbeat message with key 1 pressed

32. Key-state message period (77h)

This message sets the period time for the PERIODIC KEY-STATE TRANSMISSION (71h).

Byte 0	04h	Header bytes
Byte 1	1Bh	
Byte 2	77h	Key-state message period
Byte 3	XXh	XX: Period in milliseconds ÷ 10 From 05h (50ms) to FEh (2.54 sec)
Byte 4,7	FFh	Not used

Example:

Direction	Identifier	Format	Message	Data
To Keypad	18EF2100h	Ext	04 1B 77 05 FF FF FF FF	Period set to 50ms

33. Start Demo mode(7Ah)

This message enables the Demo mode function. Demo mode is a special feature that consists in different LED states for each button pressing. Refer to the appendix “Demo mode instructions” to try these special features. Disconnect and reconnect the keypad after sending the message to enter this mode. To exit the Demo mode, send the Disable Demo mode command or another command message.

Byte 0	04h	Header bytes
Byte 1	1Bh	
Byte 2	7Ah	Start Demo mode
Byte 3	XXh	XX: 00h Disabled (Default) 01h Enabled
Byte 4,7	FFh	Not used

Example:

Direction	Identifier	Format	Message	Data
To Keypad	18EF2100h	Ext	04 1B 7A 01 FF FF FF FF	Demo mode enabled

34. Default backlight brightness level (7Bh)

This message sets the default value of the backlight brightness level. The value can be set from 0 to 3Fh (0-100%) of the brightness range.

Byte 0	04h	Header bytes
Byte 1	1Bh	
Byte 2	7Bh	Default backlight brightness level
Byte 3	XXh	XX: Value From 00h (0%) to 3Fh (100%)
Byte 4,7	FFh	Not used

Example:

Direction	Identifier	Format	Message	Data
To Keypad	18EF2100h	Ext	04 1B 7B 20 FF FF FF FF	Default backlight level set to 50%

35. Default LED indicators brightness level (7Ch)

This message sets the default value of the LED indicator brightness level. The value can be set from 0 to 3Fh (min-100%) of the LED dimming range.

Byte 0	04h	Header bytes
Byte 1	1Bh	
Byte 2	7Ch	Default LED indicators brightness level
Byte 3	XXh	XX: Value From 00h (min) to 3Fh (100%)
Byte 4,7	FFh	Not used

Example:

Direction	Identifier	Format	Message	Data
To Keypad	18EF2100h	Ext	04 1B 7C 3F FF FF FF FF	Default LED indicators brightness level set to 100%

36. Default backlight color (7Dh)

This message sets the default color of the backlight.

Byte 0	04h	Header bytes
Byte 1	1Bh	
Byte 2	7Dh	Default backlight color
Byte 3	XXh	XX: color 01: red 02: green 03: blue 04: yellow 05: cyan 06: magenta 07: white/light blue 08: amber/orange 09: yellow/green
Byte 4,7	FFh	Not used

Example:

Direction	Identifier	Format	Message	Data
To Keypad	18EF2100h	Ext	04 1B 7D 04 FF FF FF FF	Default backlight color set to yellow

37. Set CAN protocol

This set of messages are used to change to the desired CANbus protocol.

- Change from CANopen to J1939:

Direction	Identifier	Format	Message	Data
To Keypad	600h + current CAN ID (default 615h)	Std	2B FF 20 01 01	Change to J1939

- Change from J1939 to CANopen:

Direction	Identifier	Format	Message	Data
To Keypad	18EFXX00h where XXh is the current CAN source address (default 18EF2100h)	Ext	04 1B 80 00 FF FF FF FF	Change to CANopen

APPENDIX: DEMO Mode instructions

In DEMO Mode you can try the following functions by pressing keys on the PKP2300-MT.

Entering this mode, you turn the encoder LEDs 1-17 and the key-LED indicators on with red color (opening feature); each time you press the key 1 you can change the color of the indicators with the following sequence:

1. Red;
2. Green;
3. Blue;
4. Yellow;
5. Cyan;
6. Magenta;
7. White/light blue;
8. Amber;
9. Yellow/green;
10. OFF.

Holding down the key 2, you can increase LED brightness level.

Holding down the key 3, you can decrease LED brightness level.

If you press the key 4, there are different steps in this sequence:

1. Red backlight active with key 6 with red, color; by pressing the key you can change the matching LED indicator color or disable it.
2. Complete LED show of all colors;
3. Backlight active with keys on in sequence (it is possible to change the color of LED indicators by pressing key 1 and the color of the backlight by pressing key 5);
4. Alternate blinking of LED keys number 2 with amber color; 4 with green color; 5 with cyan color; 6 with white color.
5. Return to the opening feature.

If the encoders are turned, the matching LED indicators around:

- switch ON rotating clockwise;
- switch OFF rotating counterclockwise.

In the case you press the other keys there are no events.

APPENDIX 2: Input application examples

This chapter shows a list of possible input applications.

NOTE: the power supply and ground available on the Input Signal Connector must be used for the external connected devices.

1. Switch high side on input 3:

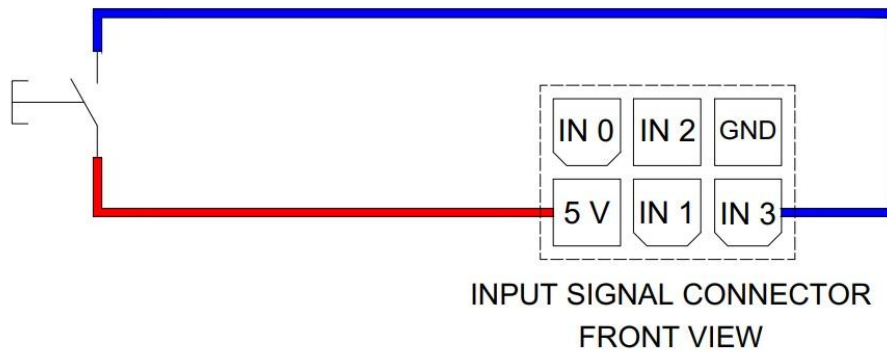

2. Switch low side on inputs 0, 1, 2, and 3:

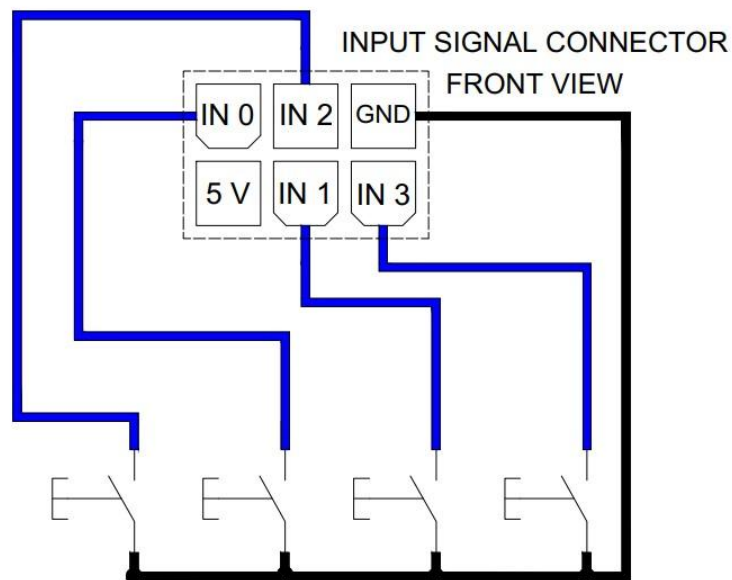

3. Digital active signal on input 2:

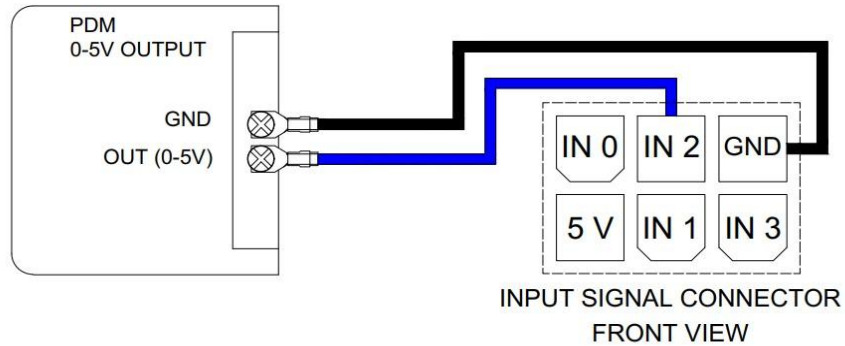

4. Active analog sensor:

- Pressure transducer – signal on input 0

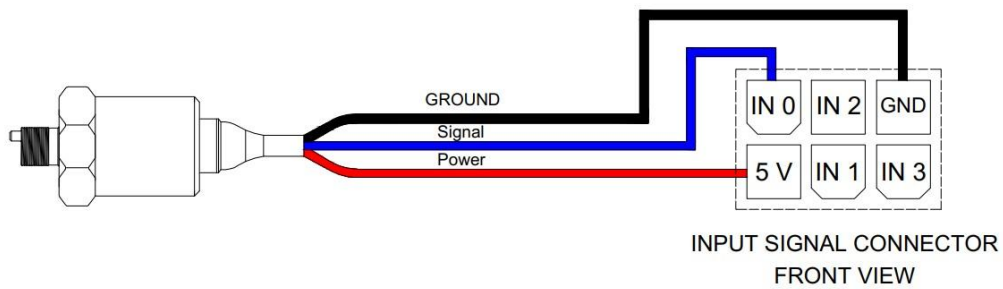

- Hall effect position sensor – signal on input 0

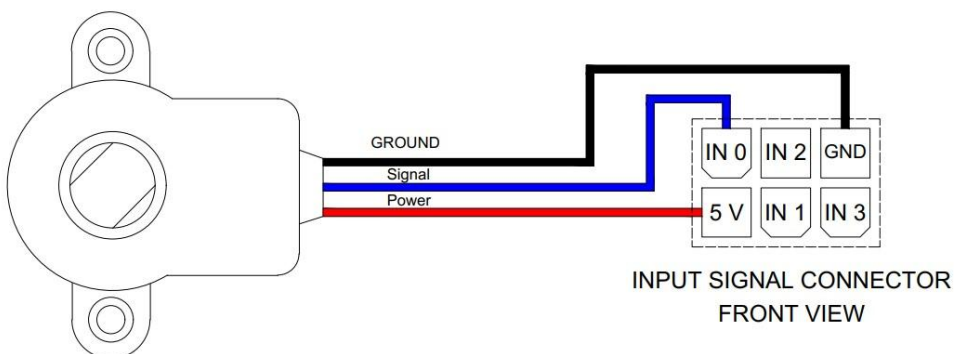

5. The use of passive sensors such as NTC thermistors, potentiometers, and all kind of variable resistors is not recommended!

38. Revision history

Date	Manual Revision	Comment
12/02/2026	1.0	First release