

R VERSION

Includes 2 rotary encoders with a rubber knob that allows for a standard PKP-SI insert to be fitted.



P VERSION

Includes 2 rotary encoders with a solid plastic knob.



PKP-3500-SI-MT

PKP-3500-SI-MT marks a notable advancement in CANbus keypads, boasting a sophisticated design with thirteen push buttons featuring replaceable icon inserts, as well as two push-enabled rotary encoders. It also includes four additional analog and digital inputs, allowing direct connection of 5V sensors to the CANbus network through the keypad. This compact layout and the rotary encoders provide significant dash space savings while enhancing vehicle functionality. The IP67/IP69K-rated PKP-3500-SI-MTB version offers increased detent torque for improved haptic feedback.

SOFTWARE FEATURES

CAN Keypad Addresses – Assign any valid CAN address to the keypad.

CANopen Communications Protocol – Fully compliant with Device Profile 401d.

J1939 Address Claim Transmission – Keypads no longer have to be pre-programmed to a specific address. This enables customers that work in applications in the field without access to a GUI to use any replacement keypad on-hand. The keypad can be configured to automatically announce its address and accept a new address assignment as appropriate.

Event Status Transmission – The keypad can send messages to the BUS indicating a button press or a button release event has occurred. This confirmation allows digital systems to have the same input acknowledgements as that of the latching position of a mechanical switch.

Periodic Status Transmission – The keypad sends a continuous broadcast of messages indicating the press or release status of each button at that instance. The frequency of these messages can be adjusted in a wide range.

Periodic Heartbeat – The keypad sends a continuous broadcast of messages indicating it is functioning correctly. The frequency of these messages can be adjusted in a wide range.

Online Set-up – An online set-up system makes it possible to select and design your own prototype, then order it directly on blinkmarine.com.

HARDWARE FEATURES

IP67/IP69K Waterproof Rating Available – BP and BR models are guaranteed to be dust tight and sealed against water immersion to a depth of 1 meter for up to 1 hour.

UV Protected – UVB 400 hours: Keypad is highly resistant to deterioration caused by exposure to sunlight.

Customizable Inserts – The replacement system for individual inserts makes modifying the keypad layout simpler and more economical. Thousands of different stock inserts can be viewed at blinkmarine.com, and it is possible to order customized ones.

A membrane compensation valve which self compensate the internal pressure within the IP67 keypad, alleviating mechanical stresses that can be produced by shifts in external temperatures.

The keypad's symmetrical design and spacing between keys makes it easier to install multiple keypads alongside one another.

The rubber is molded on the backside in such a way that it acts as a gasket, blocking liquids and preventing them from leaking in through the attachment holes located on the support upon which the keypad is installed.

Independent Key – The device is able to support any multiple pressure key combination.

Encoder With Pushbutton – Use of the knob is both comfortable and immediate. For example, the knob allows its user to manage scroll & select operations without letting go of the handle.

4 Additional 5V Inputs – Allows the possibility to connect items such as analogue active sensors (such as pressure and temperature sensors), discrete switches (highside/lowside) and Hall Effect sensors."

Independent LED Indicator Lights – Each rotary encoder has 16 Blue LED light indicators, while all 13 pushbuttons are equipped with RGB LED rings. All LEDs can be independently programmed.

STANDARD FEATURES

- Reconfigurable keys
- Replaceable icon inserts
- Configurable LED
- High intensity LED status indicators
- LED backlit icons
- Multicolor indicator rings
- Laser etched icons
- Programmable functions (momentary, toggle, scroll...)
- Thousands of stock icons to choose from
- Encoders with pushbuttons
- Vertical or horizontal mount
- Two different knob types: with or w/o replaceable icon inserts
- Protected from inverted polarity

SOFTWARE FEATURES

- Change CAN keypad addresses independently
- Periodic Status transmission
- Heartbeat
- Event status transmission
- LED acknowledgement
- Address claim transmission
- CANopen and J1939 communication protocol
- Plug-and-play reconfigurability
- Detailed user manuals available

OTHER BENEFITS

- Specific connectors and cables are available on request



ORDERING INFORMATION

	PKP-3500-SI-MT	<input type="checkbox"/>	<input type="checkbox"/>
Keypad			
IP Rating/Detent Torque	A: IP54/Standard B: IP67/Increased		
Knob Type	P: Plastic Knob R: Rubber knob with replaceable icon inserts		

SPECIFICATIONS

ELECTRICAL	PKP-3500-SI-MT
Supply Voltage	12-24Vdc Nominal (8-32VDC)
Standby Current	<50 mA
Communication BUS	CANopen, J1939
MTBF	58390 hours (in accordance with MIL-HDBK-217-operating environment ground mobile)

MECHANICAL	PKP-3500-SI-MT
Standard Connector	Deutsch DT04-4P
Inputs Connector	Molex 39-01-3069 (A), Deutsch DTM04-6P (B)
Switch Life	3 million operations
Mounting Studs	2x #10-32 Stainless Steel
Rubber Specs	Silicone rubber with polyurethane hardcoat
PCB	1,6mm thick, Nema Grade FR-4, double clad with 1 oz copper
Ticks per revolution	16
Operating Temperature	-40°C to +70°C
Storage Temperature	-40°C to +85°C
Thermal Shock	-40°C to +85°C According to table 2 of ISO16750-4
Mechanical Shock Test	IEC 60068 2-27 3-axis X,Y,Z 50Gs 11 ms
Vibration Test	IEC 60068 2-6 3-axis X,Y,Z 10-150Hz 0.15mm
UV Protection	UVB 400 hours
Salt Spray	Per ASTM B117
Chemical Resistance	Engine Cleaner, Isopropyl Alcohol, Suntan Lotion, Multi-Purpose Cleaner, Muriatic Acid
Ingress protection Rating	IP54 (A) - IP67/IP69K (B)
Weight	360 gr (Inserts excluded)

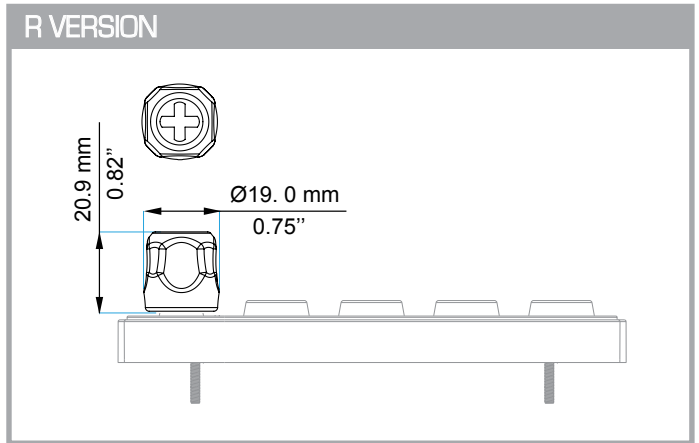
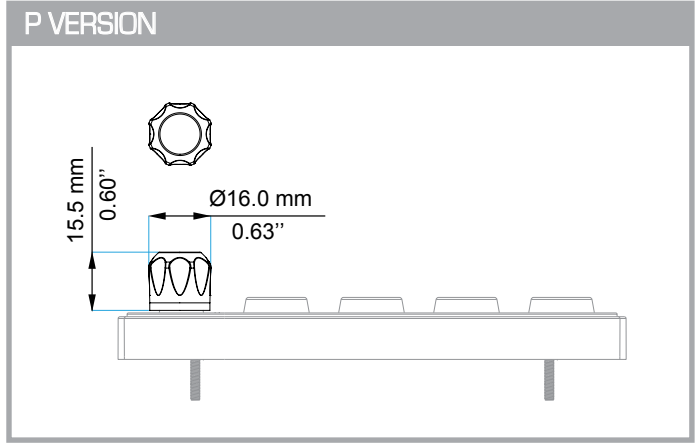
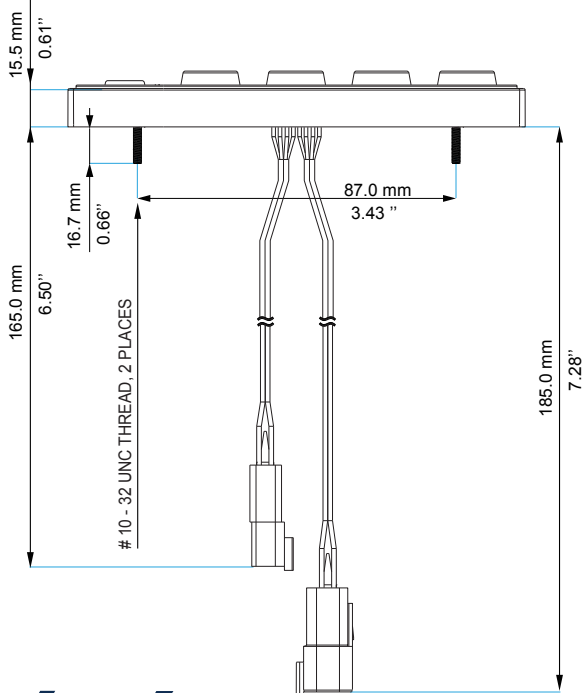
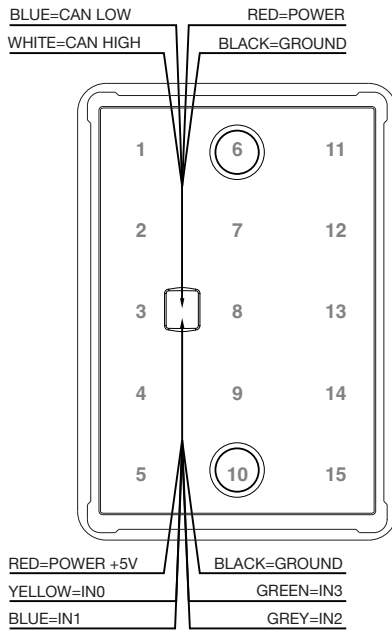
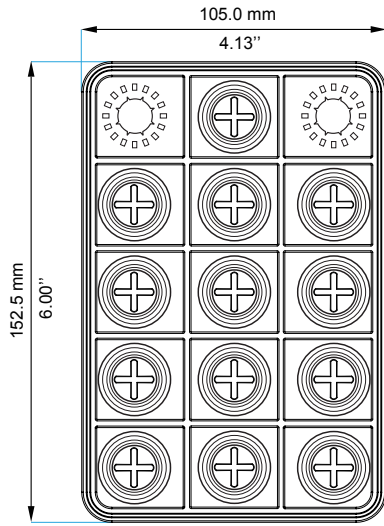

MOUNTING NOTES:
 Nuts thread: 2x #10-32
 Maximum torque: 1,0Nm - 16lbf-in

All connection wires are the same length

CONNECTORS STANDARD PINOUT*

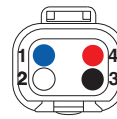

WIRE SIDE

PIN	COLOUR	FUNCTION
1	Blue	CAN L
2	White	CAN H
3	Black	Negative battery
4	Red	Vbatt. (12-24V)



WIRE SIDE

PIN	COLOUR	FUNCTION
1	Red	Power +5V
2	Yellow	IN0
3	Blue	IN1
4	Grey	IN2
5	Green	IN3
6	Black	GND

*The one illustrated above is the standard pinout; however, some keypads may be supplied with alternative pinouts or connectors.



Blink S.r.l.
 Via Montefeltro, 6 - 20156 Milano - Italy
 Tel. +39 02 3088583 - Fax +39 02 33406697
 www.blinkmarine.com - info@blinkgroup.com

!WARNING! IMPROPER SELECTION, IMPROPER USE AND/OR FAILURE OF THE BLINK SYSTEMS PRODUCTS DESCRIBED HEREIN OR RELATED ITEMS CAN CAUSE DEATH, PERSONAL INJURY AND PROPERTY DAMAGE. This document and other information from Blink, provide product and/or system options for further investigation by users having technical expertise. It is important to analyze all aspects of the application, including consequences of any failure. Due to the variety of operating conditions and applications for these product(s), the manufacturer of the application is solely responsible for marking the final selection of the product(s) and assuring that all performance, safety and warning requirements of the application are met. The products described herein, including without limitation, product features, specifications, designs, availability and pricing, are subject to change by Blink at any time without notice.