



PKP-SI Series

PKP-1600-SI, PKP-2200-SI, PKP-2300-SI, PKP-2400-SI, PKP-2500-SI, PKP-2600-SI and PKP-3500-SI are a compact keypads based on CAN protocol. They come equipped with keys with interchangeable 15 mm inserts. The keypads are water and dust resistant, and can be installed both inside and outside the cockpit. RGB led lights and the ease with which icons can be switched in and out make it possible for the user to customize each key in a wide range of variations.

SOFTWARE FEATURES

CAN Keypad Addresses – Assign any valid CAN address to the keypad.

CANopen Communications Protocol – Fully compliant with Device Profile 401d.

J1939 Address Claim Transmission – Keypads no longer have to be pre-programmed to a specific address. This enables customers that work in applications in the field without access to a GUI to use any replacement keypad on-hand. The keypad can be configured to automatically announce its address and accept a new address assignment as appropriate.

Event Status Transmission – The keypad can send messages to the BUS indicating a button press or a button release event has occurred. This confirmation allows digital systems to have the same input acknowledgements as that of the latching position of a mechanical switch.

Periodic Status Transmission – The keypad sends a continuous broadcast of messages indicating the press or release status of each button at that instance. The frequency of these messages can be adjusted in a wide range.

Periodic Heartbeat – The keypad sends a continuous broadcast of messages indicating it is functioning correctly. The frequency of these messages can be adjusted in a wide range.

Online Set-up – An online set-up system makes it possible to select and design your own prototype, then order it directly on blinkmarine.com.

HARDWARE FEATURES

IP67/IP69K Waterproof Rating – Guaranteed to be dust tight and sealed against water immersion to a depth of 1 meter for up to 1 hour. The IP69K rating provides protection against high pressure water at high temperature spray downs.

UV Protected – UVB 400 hours: Keypad is highly resistant to deterioration caused by exposure to sunlight.

Customizable Inserts – The replacement system for individual inserts makes modifying the keypad layout simpler and more economical. Thousands of different stock inserts can be viewed at blinkmarine.com, and it is possible to order customized ones.

A membrane compensation valve which self compensate the internal pressure within the keypad, alleviating mechanical stresses that can be produced by shifts in external temperatures.

The keypad's symmetrical design and spacing between keys makes it easier to install multiple keypads alongside one another.

The rubber is molded on the backside in such a way that it acts as a gasket, blocking liquids and preventing them from leaking in through the attachment holes located on the support upon which the keypad is installed.

Independent Key – The device is able to support any multiple pressure key combination.

STANDARD FEATURES

- Reconfigurable keys
- Replaceable icon inserts
- Configurable LED
- High intensity LED status indicators
- LED backlit icons
- Multicolor indicator rings
- Laser etched icons
- Programmable functions (momentary, toggle, scroll...)
- Thousands of stock icons to choose from
- Vertical or horizontal mount
- Protected from inverted polarity

SOFTWARE FEATURES

- Change CAN keypad addresses independently
- Periodic status transmission
- Heartbeat
- Event status transmission
- LED acknowledgement
- Address claim transmission
- CANopen and J1939 communication protocol
- Plug-and-play reconfigurability
- Detailed user manuals available

OTHER BENEFITS

- Specific connectors and cables are available on request



SPECIFICATIONS FOR STANDARD KEYPADS

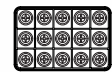

ELECTRICAL	PKP-1600-SI	PKP-2200-SI	PKP-2300-SI	PKP-2400-SI	PKP-2500-SI	PKP-2600-SI	PKP-3500-SI
Supply Voltage	12-24Vdc Nominal (8-32VDC)						
Standby Current	<50 mA						
Communication BUS	CANopen, J1939						
MTBF	203990	240512	239870	238506	178005	204291	173498
	hours (in accordance with MIL-HDBK-217-operating environment ground mobile)						

MECHANICAL

Standard Connector	Deutsch DT04-4P						
Switch Life	3 million operations						
Mounting Studs	2x #10-32 Stainless Steel						
Rubber Specs	Silicone rubber with polyurethane hardcoat						
PCB	1,6mm thick, Nema Grade FR-4, double clad with 1oz copper						
Operating Temperature	-40°C to +70°C						
Storage Temperature	-40°C to +85°C						
Thermal Shock	-40°C to +85°C According to table 2 of ISO16750-4						
Mechanical Shock Test	IEC 60068 2-27 3-axis X,Y,Z 50Gs 11 ms						
Vibration Test	IEC 60068 2-6 3-axis X,Y,Z 10-150Hz 0.15mm						
UV Protection	UVB 400 hours						
Salt Spray	Per ASTM B117						
Chemical Resistance	Engine Cleaner, Isopropyl Alcohol, Suntan Lotion, Multi-Purpose Cleaner, Muriatic Acid						
Ingress protection Rating	IP67/IP69K						
Weight	130 gr*	110 gr*	140 gr*	180 gr*	200 gr*	230 gr*	300 gr*

*insert excluded



PKP-1600-SI

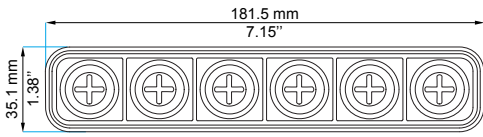

BLUE=CAN LOW
WHITE=CAN HIGH
RED=POWER
BLACK=GROUND

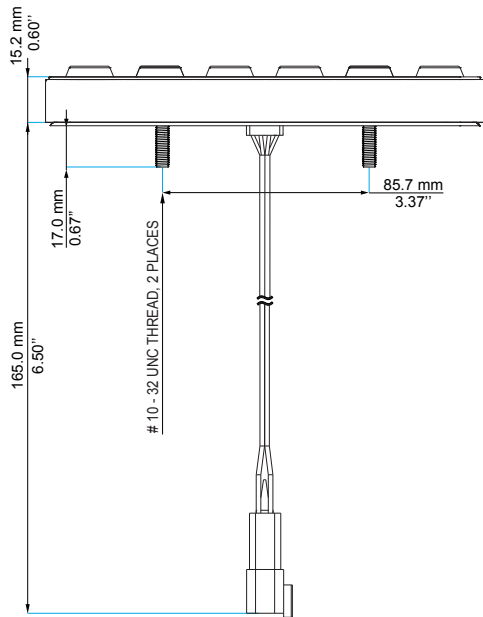
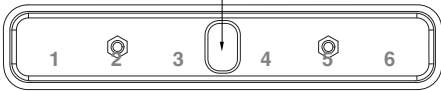

MOUNTING NOTES:
Nuts thread: 2x #10-32
Maximum torque: 1,8Nm - 16lbf-in
All connection wires are the same length



WIRE SIDE

CONNECTOR STANDARD PINOUT

PIN	COLOUR	FUNCTION
1	Blue	CAN L
2	White	CAN H
3	Black	Negative battery
4	Red	Vbatt. [12-24V]

The one illustrated above is the standard pinout; however, some keypads may be supplied with alternative pinouts or connectors.

PKP-2200-SI

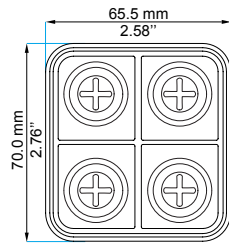

BLUE=CAN LOW
WHITE=CAN HIGH
RED=POWER
BLACK=GROUND

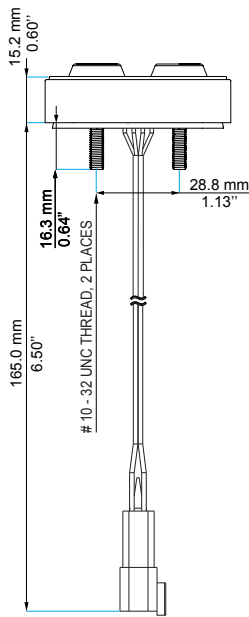
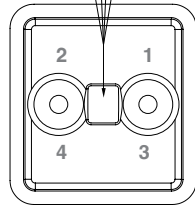

MOUNTING NOTES:
Nuts thread: 2x #10-32
Maximum torque: 1,0Nm - 9lbf-in
All connection wires are the same length

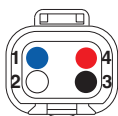

WIRE SIDE

CONNECTOR STANDARD PINOUT

PIN	COLOUR	FUNCTION
1	Blue	CAN L
2	White	CAN H
3	Black	Negative battery
4	Red	Vbatt. [12-24V]

The one illustrated above is the standard pinout; however, some keypads may be supplied with alternative pinouts or connectors.

PKP-2300-SI

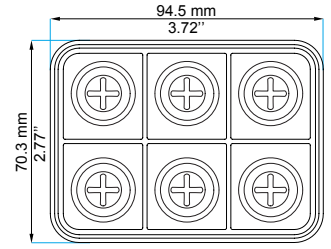

BLUE=CAN LOW
WHITE=CAN HIGH
RED=POWER
BLACK=GROUND

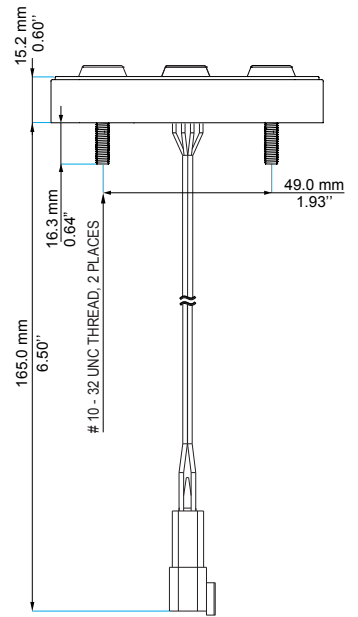
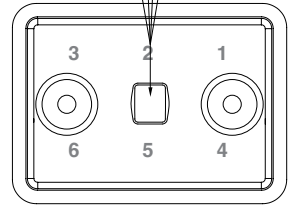

MOUNTING NOTES:
Nuts thread: 2x #10-32
Maximum torque: 1,0Nm - 9lbf-in
All connection wires are the same length

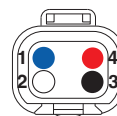

WIRE SIDE

CONNECTOR STANDARD PINOUT

PIN	COLOUR	FUNCTION
1	Blue	CAN L
2	White	CAN H
3	Black	Negative battery
4	Red	Vbatt. [12-24V]

The one illustrated above is the standard pinout; however, some keypads may be supplied with alternative pinouts or connectors.

PKP-2400-SI

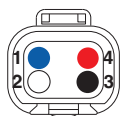
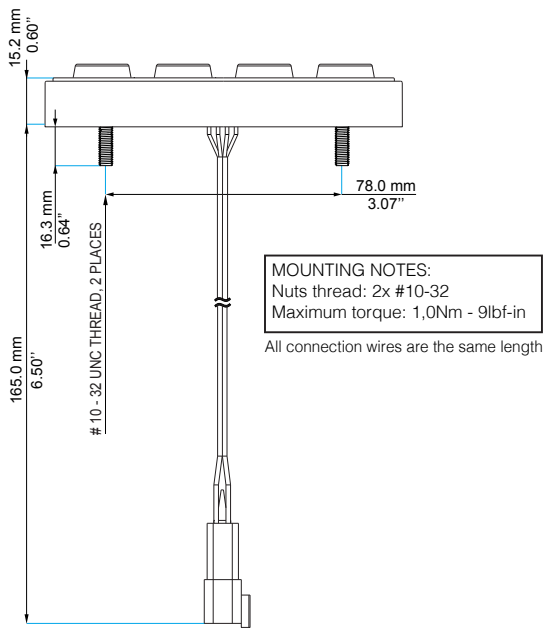
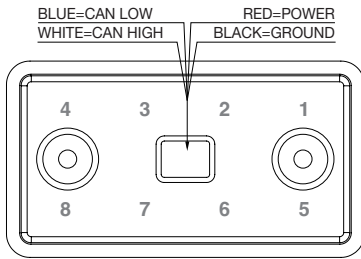
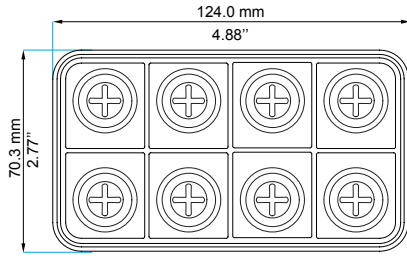

WIRE SIDE

CONNECTOR STANDARD PINOUT

PIN	COLOUR	FUNCTION
1	Blue	CAN L
2	White	CAN H
3	Black	Negative battery
4	Red	Vbatt. [12-24V]

The one illustrated above is the standard pinout; however, some keypads may be supplied with alternative pinouts or connectors.

PKP-2500-SI

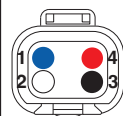
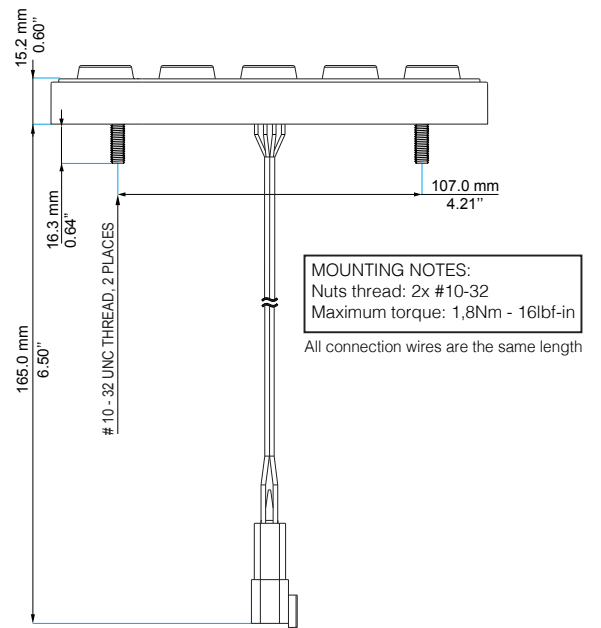
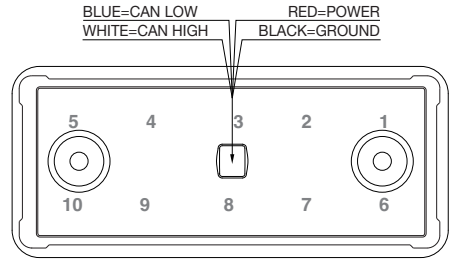
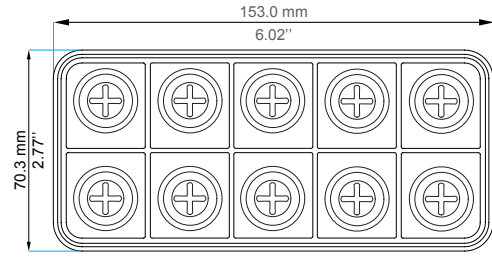

WIRE SIDE

CONNECTOR STANDARD PINOUT

PIN	COLOUR	FUNCTION
1	Blue	CAN L
2	White	CAN H
3	Black	Negative battery
4	Red	Vbatt. [12-24V]

The one illustrated above is the standard pinout; however, some keypads may be supplied with alternative pinouts or connectors.

PKP-2600-SI

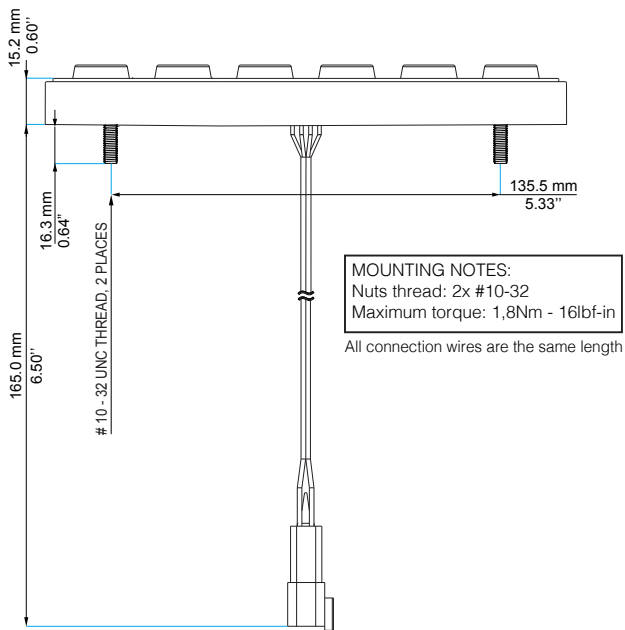
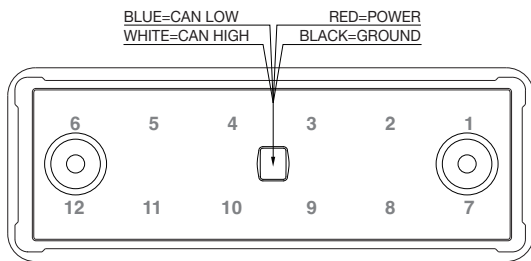
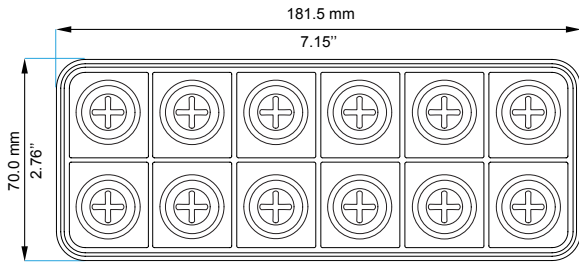

CONNECTOR STANDARD PINOUT

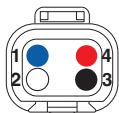

WIRE SIDE

PIN	COLOUR	FUNCTION
1	Blue	CAN L
2	White	CAN H
3	Black	Negative battery
4	Red	Vbatt. (12-24V)

The one illustrated above is the standard pinout; however, some keypads may be supplied with alternative pinouts or connectors.

PKP-3500-SI

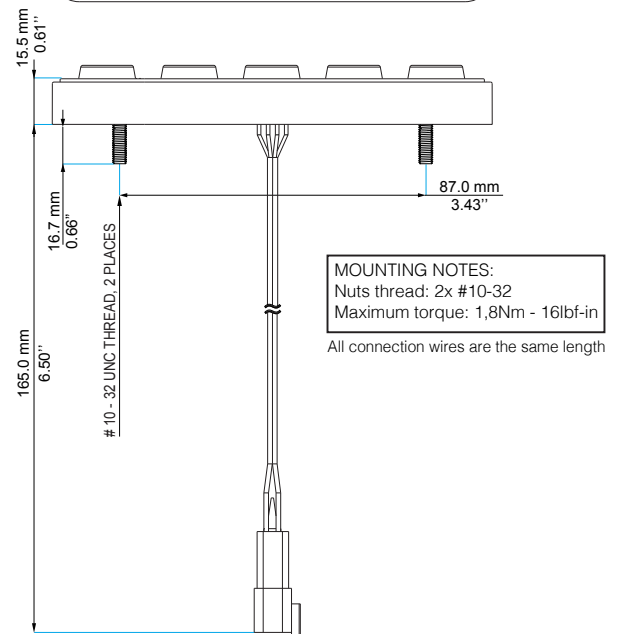
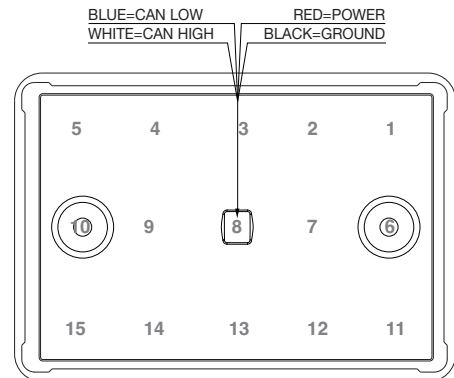
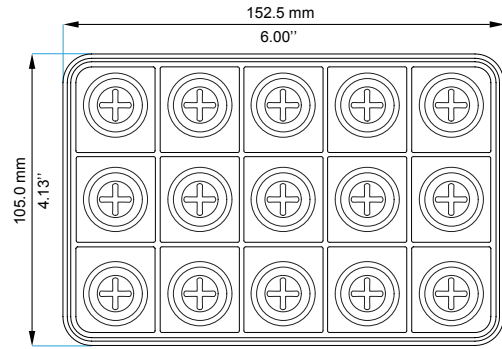

CONNECTOR STANDARD PINOUT

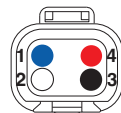

WIRE SIDE

PIN	COLOUR	FUNCTION
1	Blue	CAN L
2	White	CAN H
3	Black	Negative battery
4	Red	Vbatt. (12-24V)

The one illustrated above is the standard pinout; however, some keypads may be supplied with alternative pinouts or connectors.



Blink S.r.l.
Via Montefeltro, 6 - 20156 Milano - Italy
Tel. +39 02 3088583 - Fax +39 02 33406697
www.blinkmarine.com - info@blinkgroup.com

!WARNING! IMPROPER SELECTION, IMPROPER USE AND/OR FAILURE OF THE BLINK SYSTEMS PRODUCTS DESCRIBED HEREIN OR RELATED ITEMS CAN CAUSE DEATH, PERSONAL INJURY AND PROPERTY DAMAGE. This document and other information from Blink, provide product and/or system options for further investigation by users having technical expertise. It is important to analyze all aspects of the application, including consequences of any failure. Due to the variety of operating conditions and applications for these product(s), the manufacturer of the application is solely responsible for marking the final selection of the product(s) and assuring that all performance, safety and warning requirements of the application are met. The products described herein, including without limitation, product features, specifications, designs, availability and pricing, are subject to change by Blink at any time without notice.