



## PWTR4

**PWTR4** embodies an advanced CANbus keypad, featuring a rotary encoder and robust IP67 protection. The 4 quick-select buttons seamlessly complement the functionality of the pushable rotary encoder, which is also available in a joystick version (PWTR4-J).

This combination provides precise and intuitive control of onboard displays, putting everything at your fingertips. Customization is tailored to your needs, offering a wide range of options to make your PWTR4 truly unique. You can personalize the rubber artwork, LED color of each button, and backlighting, and even have the option to incorporate a custom logo on the knob. PWTR4 is available with both CANopen and J1939 protocols to suit your specific requirements.

### SOFTWARE FEATURES

**CAN Keypad Addresses** – Assign any valid CAN address to the keypad.

**CANopen Communications Protocol** – Fully compliant with Device Profile 401d.

**J1939 Address Claim Transmission** – Keypads no longer have to be pre-programmed to a specific address. This enables customers that work in applications in the field without access to a GUI to use any replacement keypad on-hand. The keypad can be configured to automatically announce its address and accept a new address assignment as appropriate.

**Event Status Transmission** – The keypad can send messages to the BUS indicating a button press event or a button release event has occurred. The event that triggers the message can also be caused by the movement of the joystick or the rotation of the encoder.

**Periodic Status Transmission** – The keypad sends a continuous broadcast of messages, indicating the status of each button, as well as the positions of the joystick and the encoder at that instance. The frequency of these messages can be adjusted in a wide range.

**Periodic Heartbeat** – The keypad sends a continuous broadcast of messages indicating it is functioning correctly. The frequency of these messages can be adjusted in a wide range.

**Smart LED Management** – Each light spot consists of three different colored LEDs (RGB). In this way it is possible to independently adjust color and intensity gradient of light spots.

### HARDWARE FEATURES

**IP67/IP69K Waterproof Rating** – Guaranteed to be dust tight and sealed against water immersion to a depth of 1 meter for up to 1 hour. The IP69K rating provides protection against high pressure water at high temperature spray downs.

**UV Protected** – UVB 400 hours: Keypad is highly resistant to deterioration caused by exposure to sunlight.

**A membrane compensation valve** which self compensate the internal pressure within the keypad, alleviating mechanical stresses that can be produced by shifts in external temperatures.

**The rubber is molded on the backside** in such a way that it acts as a gasket, blocking liquids and preventing them from leaking in through the attachment holes located on the support upon which the keypad is installed.

**Independent Key** – The device is able to support any multiple pressure key combination.

**Ergonomic Knob** – This controller is designed for a comfortable grip in any situation, thanks to the textured sides of the aluminum knob.

**Encoder With Pushbutton** – Use of the knob is both comfortable and immediate. For example, the knob allows its user to manage scroll & select operations without letting go of the handle.

**RGB LED** – Both the LED points on each key and the backlighting can be calibrated to display various colors within the RGB spectrum.



### STANDARD FEATURES

- Configurable LED
- Multicolor LED backlight
- High intensity LED status indicators
- RGB LED Indicators
- LED backlit icons
- Programmable functions (momentary, toggle, scroll...)
- Flush mount design
- Vertical or horizontal mount
- Protected from inverted polarity
- Available with or without joystick function

### SOFTWARE FEATURES

- Change CAN keypad addresses independently
- Periodic Status transmission
- Heartbeat
- Event status transmission
- LED acknowledgement
- Address claim transmission
- CANopen and J1939 communication protocol
- Plug-and-play reconfigurability
- Detailed user manuals available

### OTHER BENEFITS

- Custom laser etched icons
- Specific connectors and cables are available on request
- Anodized color options for the knob
- Custom knob shape
- Pad printed logo

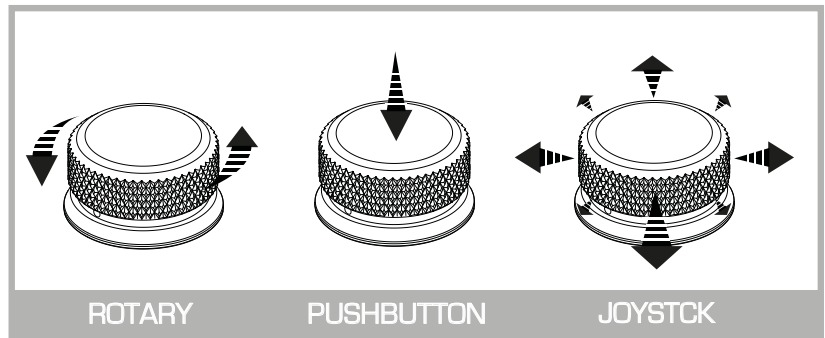

PWTR4



Without Joystick

PWTR4-J



With Joystick

### SPECIFICATIONS FOR STANDARD KEYPADS

ELECTRICAL	PWTR4	PWTR4-J
Supply Voltage	12-24Vdc Nominal (8-32VDC)	
Standby Current	<50 mA	
Communication BUS	CANopen, J1939	
MTBF	126756 hours (in accordance with MIL-HDBK-217-operating environment ground mobile)	

MECHANICAL	PWTR4	PWTR4-J
Standard Connector	Deutsch DT04-4P	
Switch Life	3 million operations	
Mounting Studs	2x #10-32 Stainless Steel	
Rubber Specs	Silicone rubber with polyurethane hardcoat	
PCB	1,6mm thick, Nema Grade FR-4, double clad with 1oz copper	
Ticks per revolution	20	20
Operating Temperature	-40°C to +70°C	
Storage Temperature	-40°C to +85°C	
Thermal Shock	-40°C to +85°C According to table 2 of ISO16750-4	
Mechanical Shock Test	IEC 60068 2-27 3-axis X,Y,Z 50Gs 11ms	
Vibration Test	IEC 60068 2-6 3-axis X,Y,Z 10-150Hz 0.15mm	
UV Protection	UVB 400 hours	
Salt Spray	Per ASTM B117	
Chemical Resistance	Engine Cleaner, Isopropyl Alcohol, Suntan Lotion, Multi-Purpose Cleaner, Muriatic Acid	
Ingress protection Rating	IP67/IP69K	
Weight	190 gr	200 gr

JOYSTICK	PWTR4	PWTR4-J
Activation Force	N/A	5.5±3.5N (560±350gf)
Max. Angle	N/A	6°
Operation Life	N/A	500.000 cycles min.

OPTION MOUNT

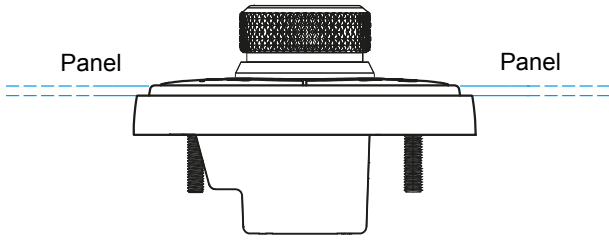

FLUSH MOUNT

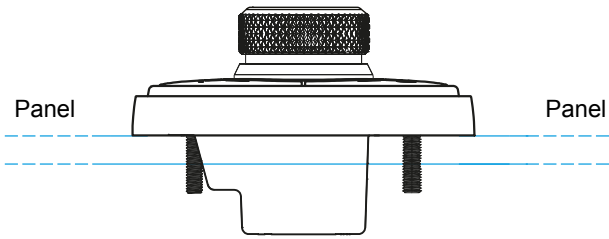
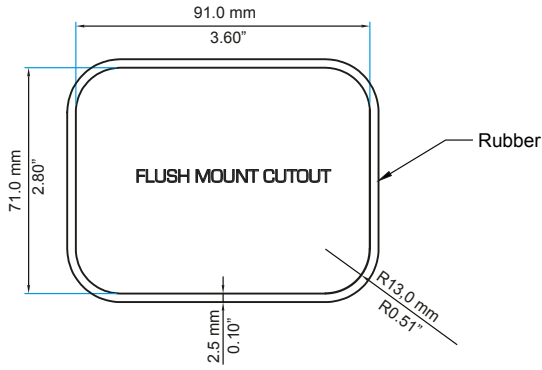

SURFACE MOUNT

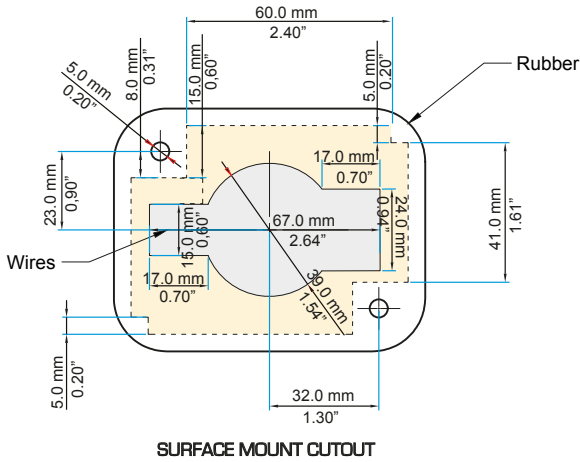

SURFACE MOUNT CUTOUT

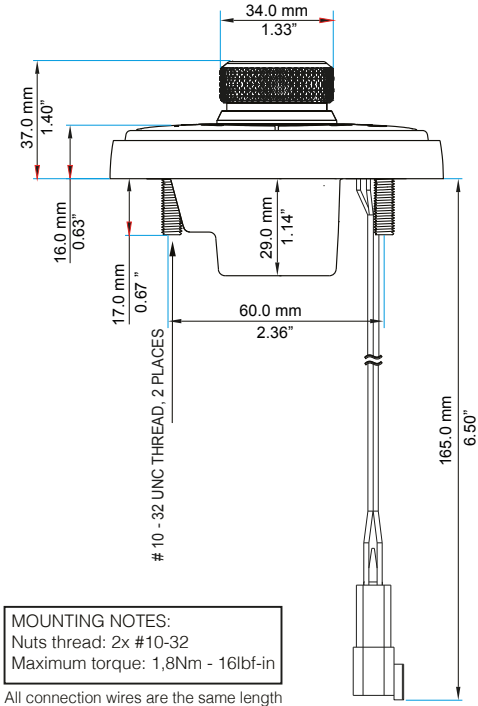
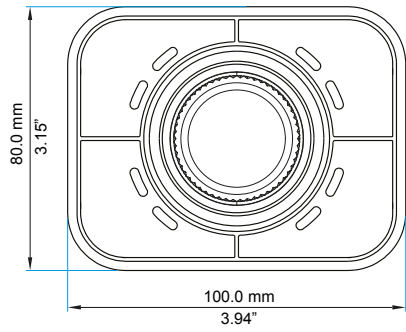
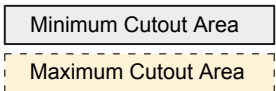

MOUNTING NOTES:  
Nuts thread: 2x #10-32  
Maximum torque: 1,8Nm - 16lbf-in  
All connection wires are the same length

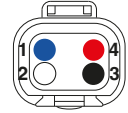
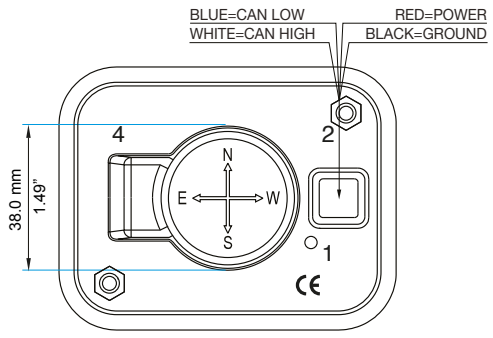

WIRE SIDE

CONNECTOR STANDARD PINOUT

PIN	COLOUR	FUNCTION
1	Blue	CAN L
2	White	CAN H
3	Black	Negative battery
4	Red	Vbatt. [12-24V]

The one illustrated above is the standard pinout; however, some keypads may be supplied with alternative pinouts or connectors.



**Blink S.r.l.**  
Via Montefeltro, 6 - 20156 Milano - Italy  
Tel. +39 02 3088583 - Fax +39 02 33406697  
[www.blinkmarine.com](http://www.blinkmarine.com) - [info@blinkgroup.com](mailto:info@blinkgroup.com)

!WARNING! IMPROPER SELECTION, IMPROPER USE AND/OR FAILURE OF THE BLINK SYSTEMS PRODUCTS DESCRIBED HEREIN OR RELATED ITEMS CAN CAUSE DEATH, PERSONAL INJURY AND PROPERTY DAMAGE. This document and other information from Blink, provide product and/or system options for further investigation by users having technical expertise. It is important to analyze all aspects of the application, including consequences of any failure. Due to the variety of operating conditions and applications for these product(s), the manufacturer of the application is solely responsible for marking the final selection of the product(s) and assuring that all performance, safety and warning requirements of the application are met. The products described herein, including without limitation, product features, specifications, designs, availability and pricing, are subject to change by Blink at any time without notice.